

FABRICATION OF COMPONENTS AS PER DWG.

1. THE ORDER SHOULD NOT BE PREFERABLY SPLITTED. THE COMPREHENSIVE QUOTE CONSIDERING FABRICATION/FITMENT OF ALL COMPONENTS, FOR CSIO WILL BE CONSIDERED. MATERIAL BSLL168/AL ALLOY WILL BE PROVIDED BY CSIO
2. THE REQUIRED QUANTITY IS 2 NOS EACH AND COMPONENTS SHOULD BE SEALED /PACKED AS PER THE ORIGINAL FACTORY PACKING. IF FOUND DAMAGED, WILL BE RETURNED.
3. THE PRICE SHOULD BE INCLUDING EX-CSIO DELIVERY.
4. THE VALID COC/INSPECTION REPORT SHOULD BE SHARED.
5. PAYMENT AND OTHER THINGS AS PER CSIO NORMS.
6. PL MAIL AT HEAD.PME@CSIO.RES.IN, HARRY.GARG@CSIO.RES.IN
7. QUOTE TIME 7 DAYS FROM DATE OF TENDER.
8. THE DETAILS OF USER WILL NOT BE SHARED.
9. FABRICATOR TO SHARE THE DELIVERY TIMELINES WITH QUOTE AFTER RECEIVING PO. FABRICATOR OF COMPONENTS/ PO IS PURELY THE PREROGATIVE OF CSIO.
10. PL QUOTE WITH 18% GST AND DELIVERY TIMELINES OF 90 DAYS. SHARE AND ATTACH RELEVANT COMPANY DOCUMENTS.
11. KINDLY FILL ALL THE RELEVANT FIELDS MENTIONED IN THE TENDER AND STRIKEOUT WHICHEVER IS NOT APPLICABLE.

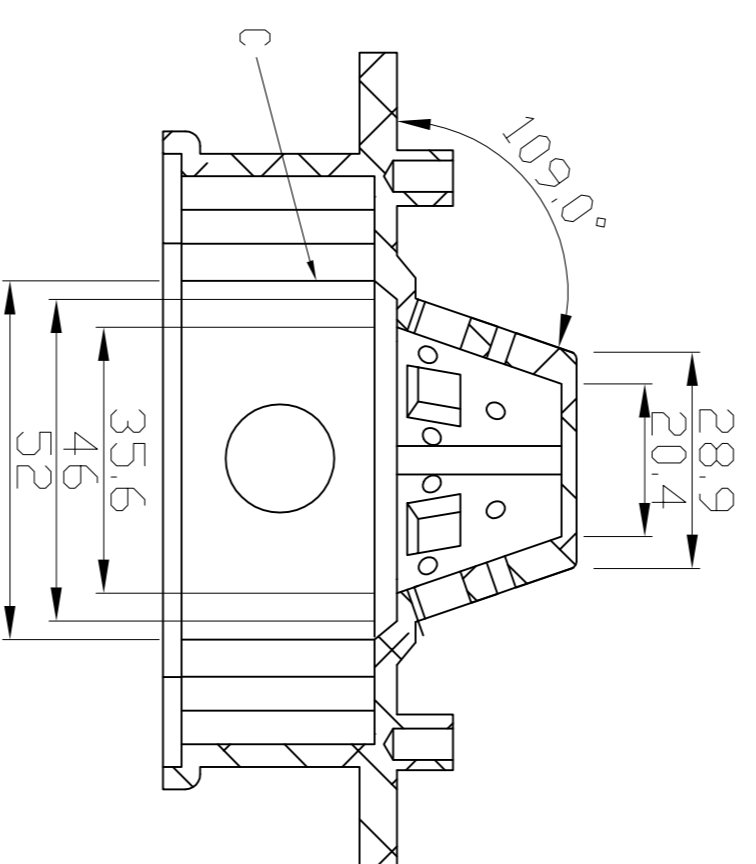

SECTION E-E

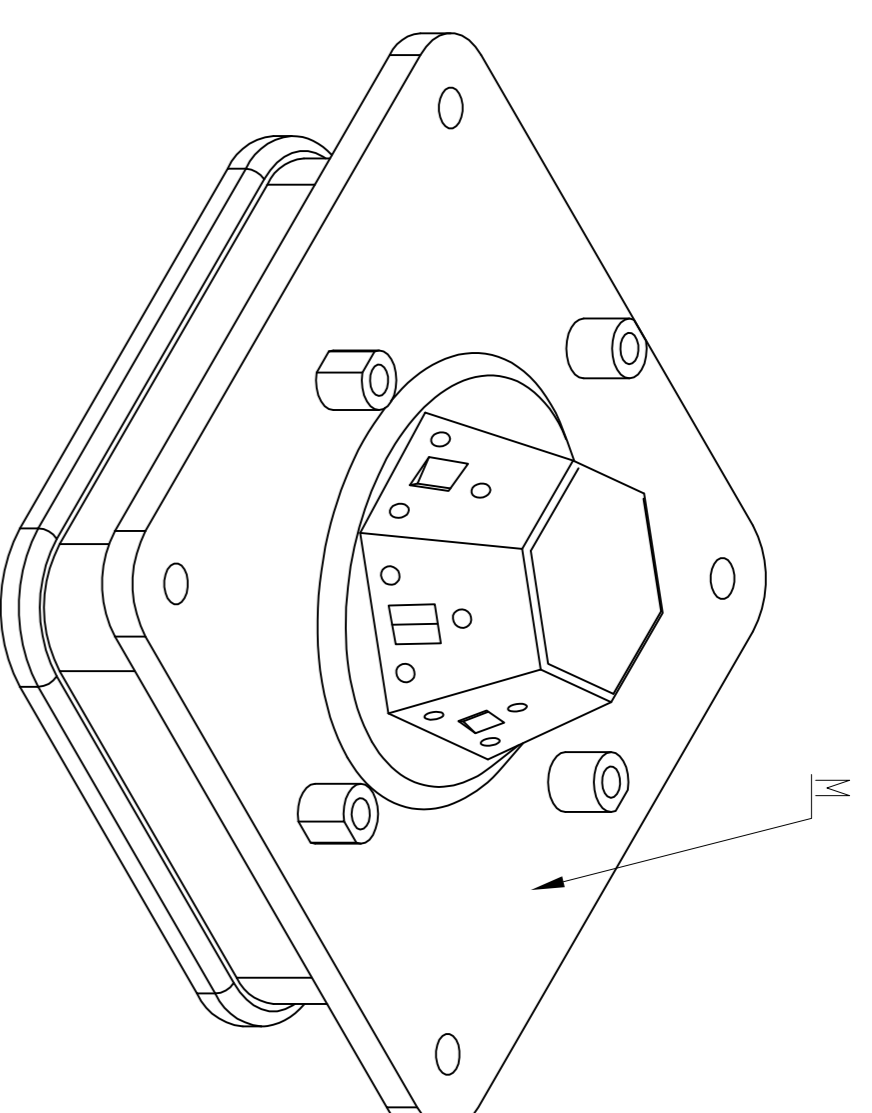
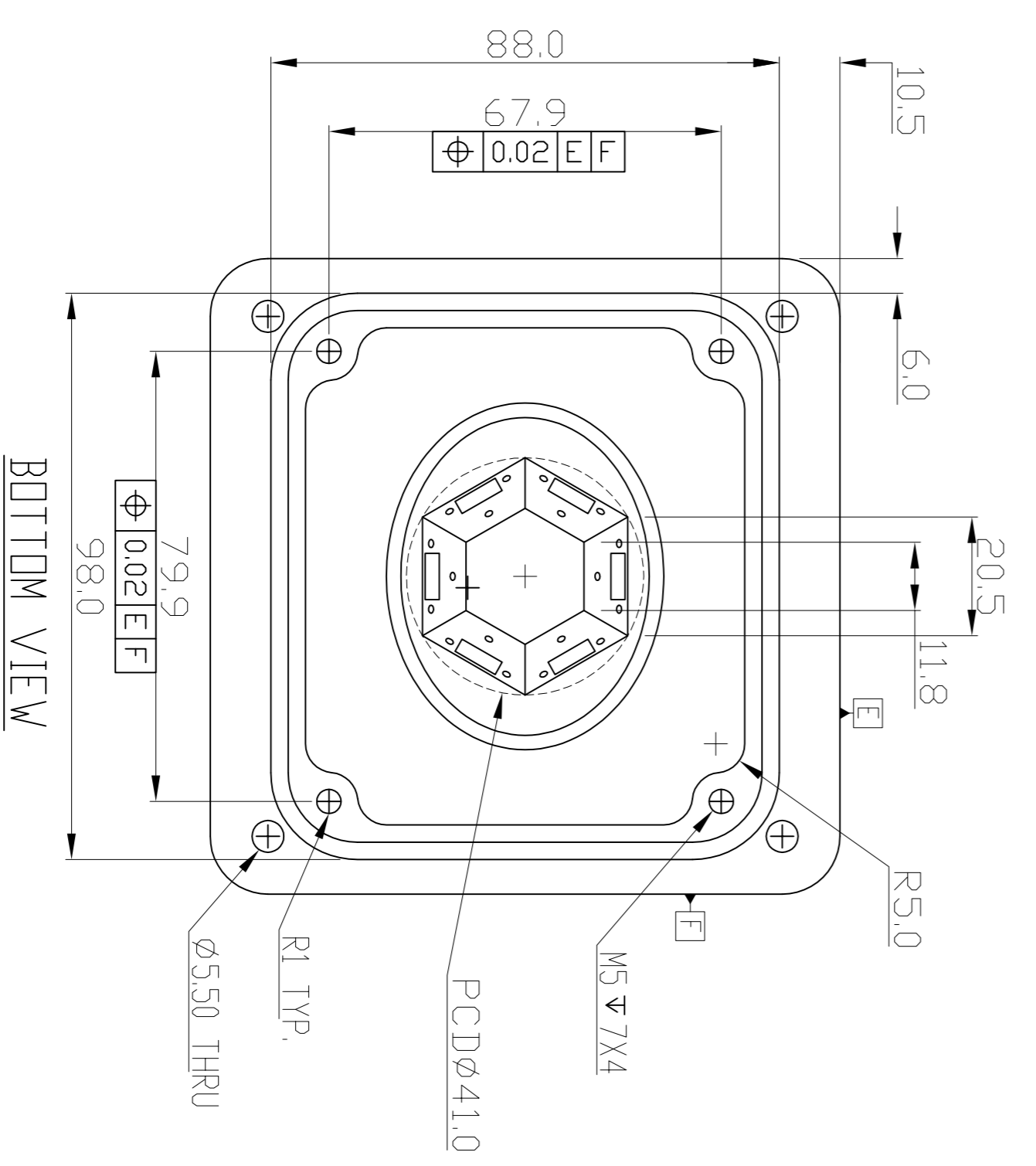
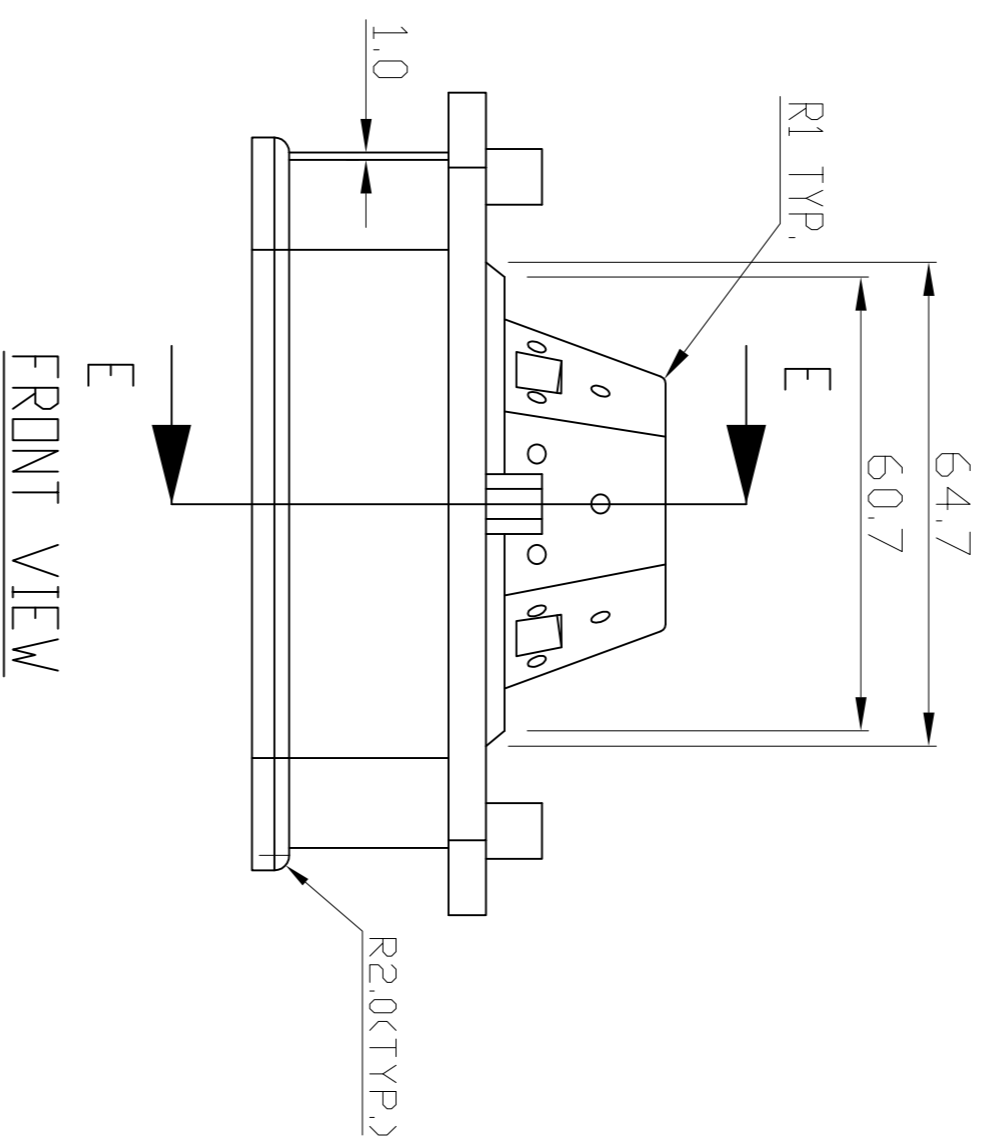
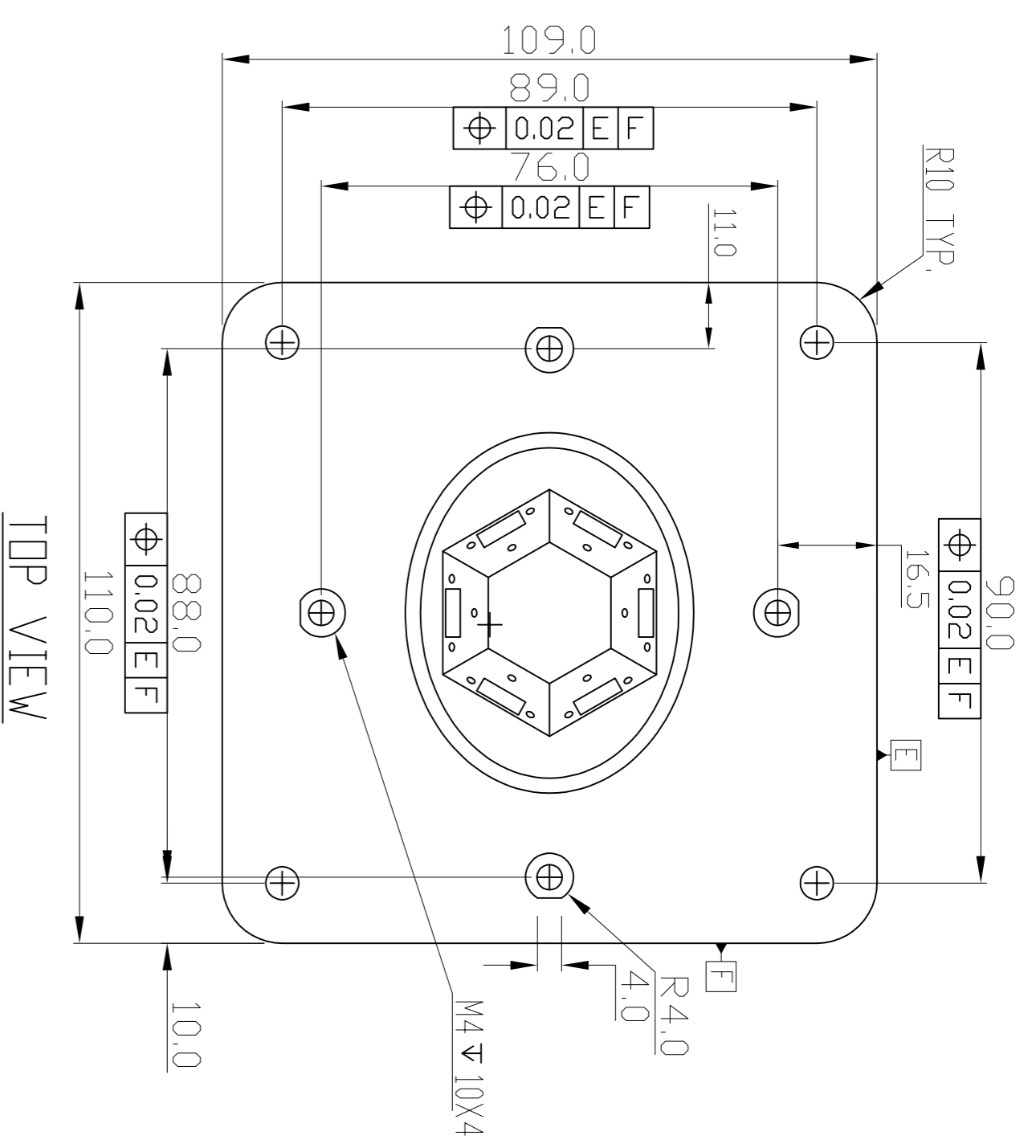
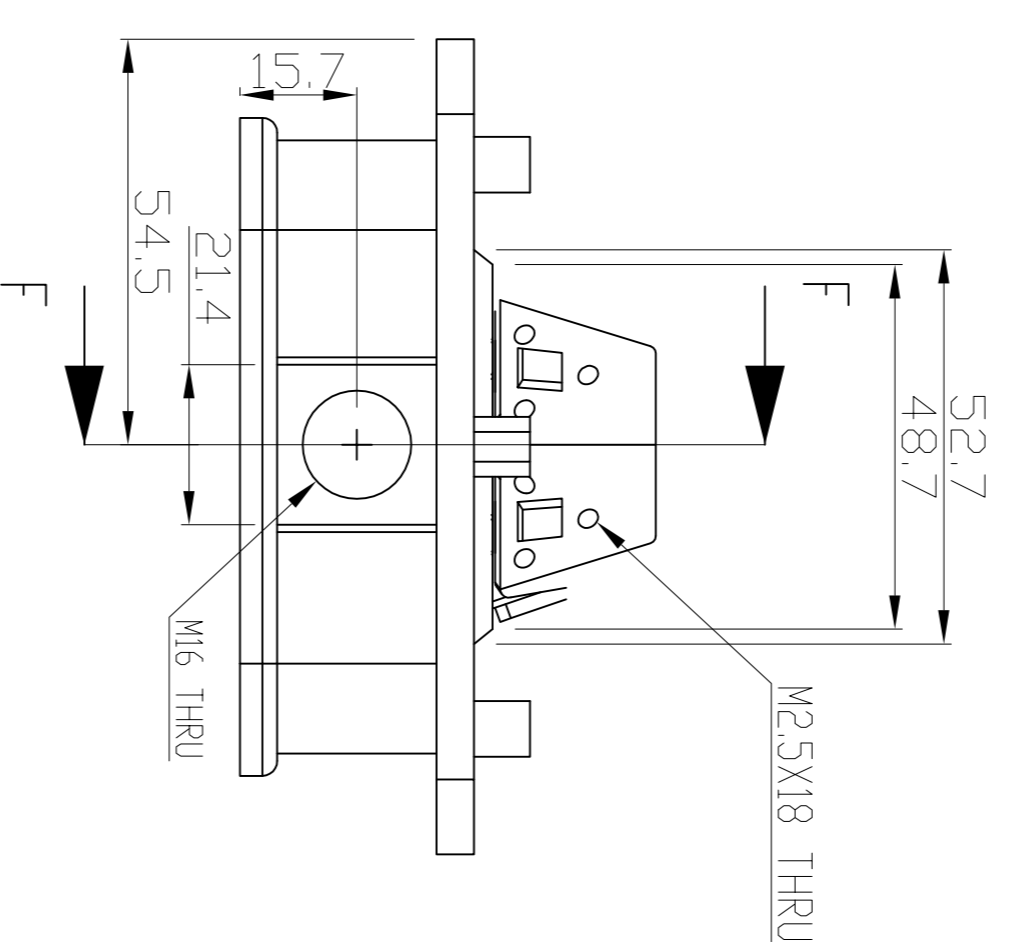

SIDE VIEW

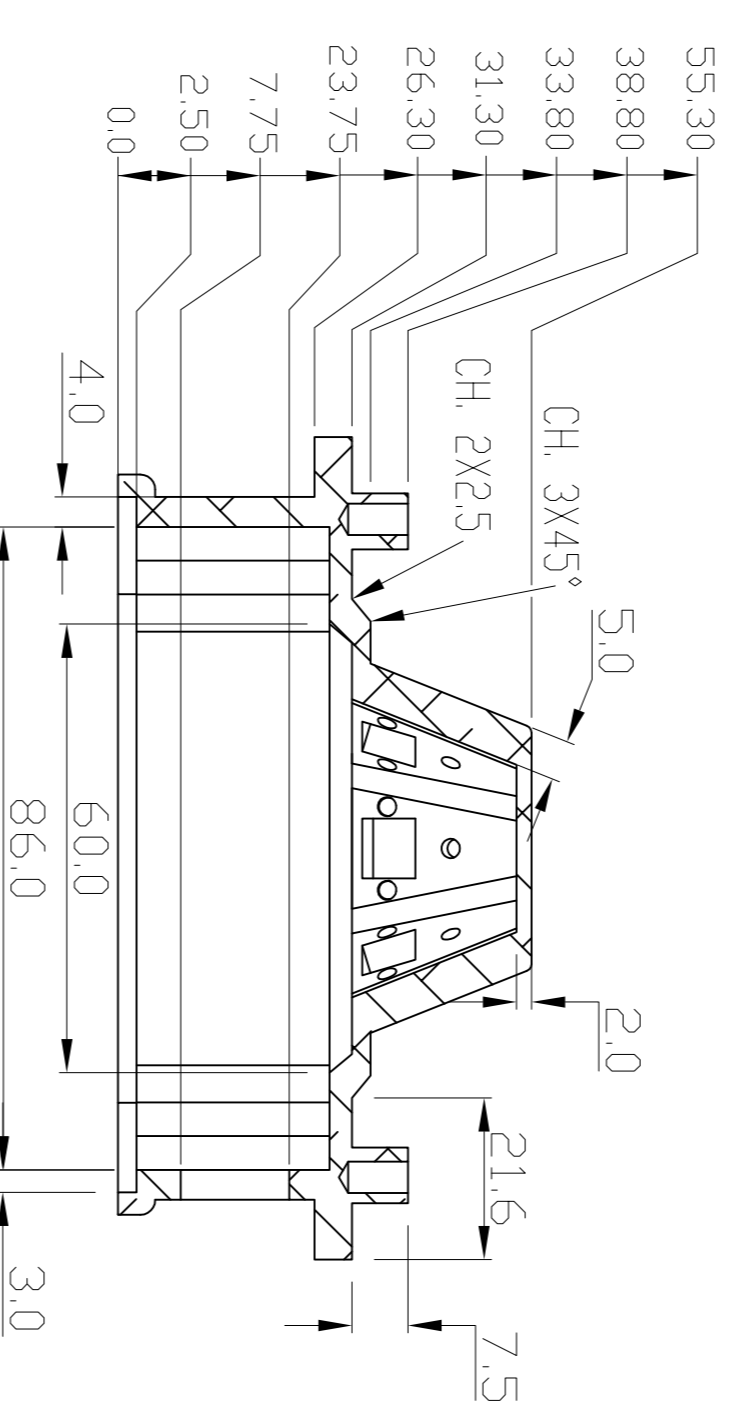
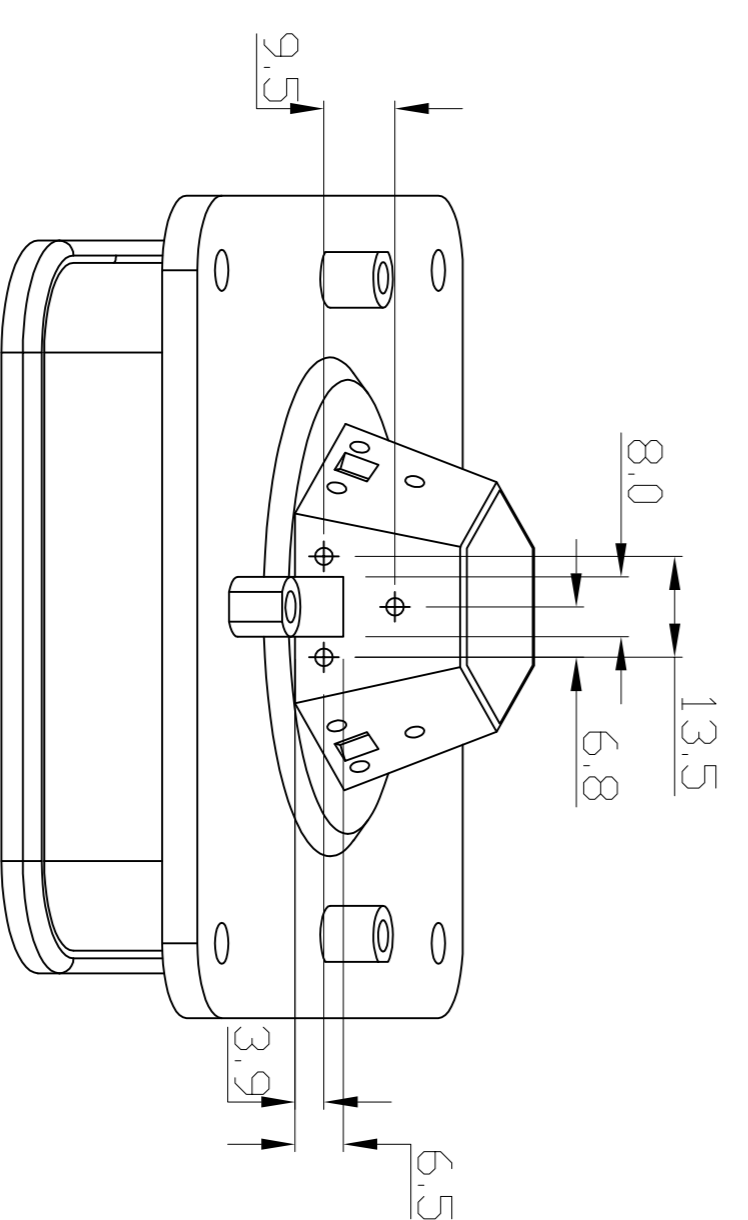

SECTION F-F

- NOTES:
1. DRAWING IS IN THIRD ANGLE OF PROJECTION.
 2. ALL DIMENSION ARE IN MM.

COMPONENT-1

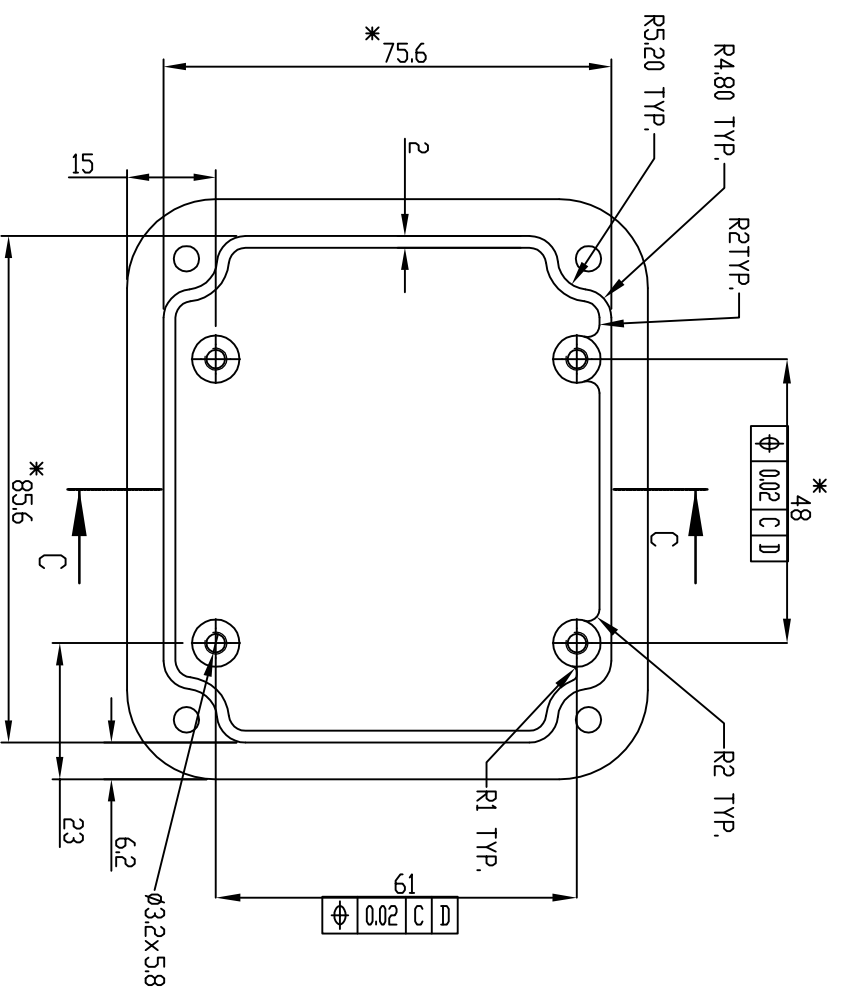

FRONT VIEW

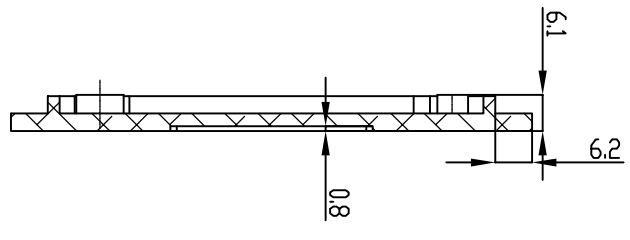

SECTION C-C

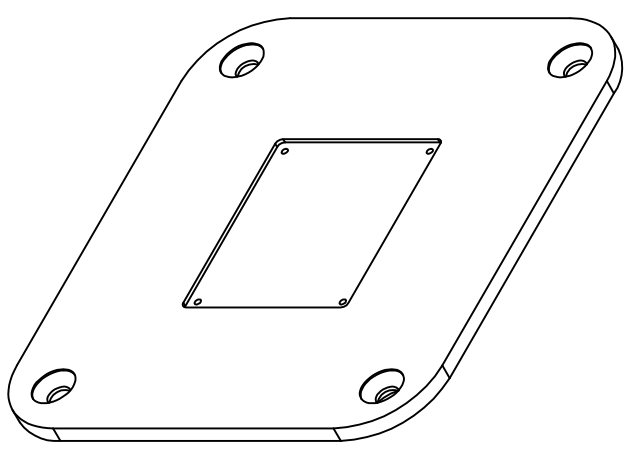

ISOMETRIC VIEW

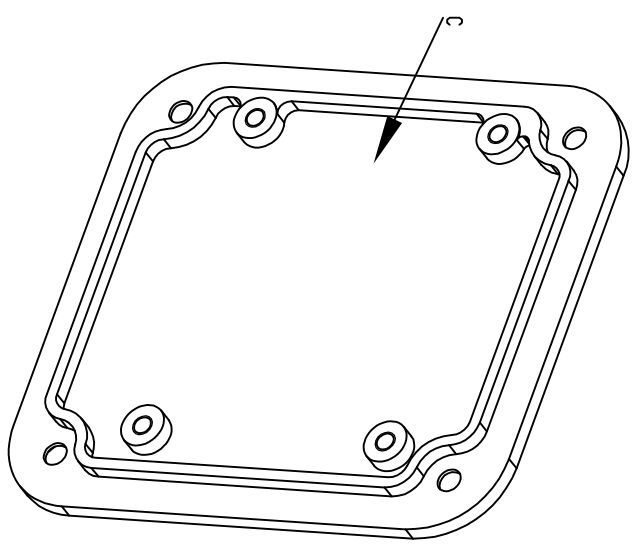

ISOMETRIC VIEW

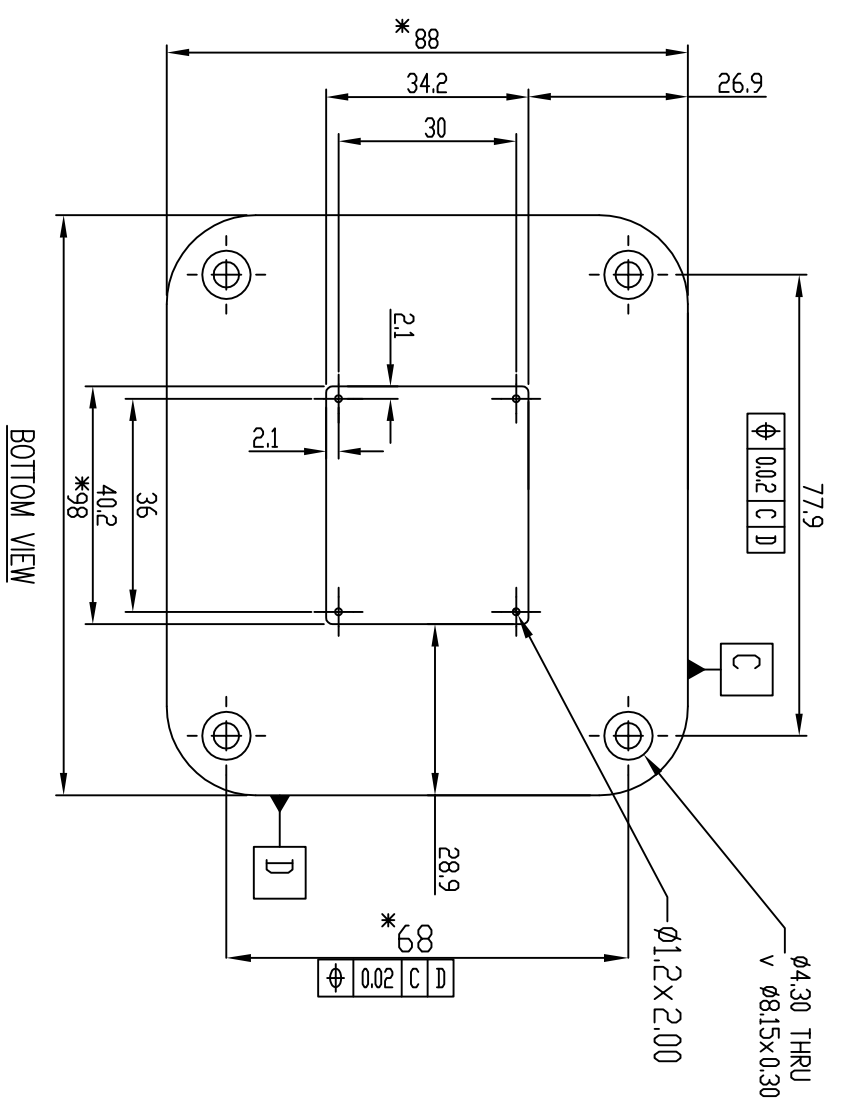

BOTTOM VIEW

- NOTES:
1. DRAWING IS IN THIRD ANGLE OF PROJECTION.
 2. ALL DIMENSION ARE IN MM.

COMPONENT-2

