

Ref: MDF/ACL/23/11/03

FABRICATION OF PCB(6 LAYERS)

1. THE ORDER SHOULD NOT BE PREFERABLY SPLITTED. THE COMPREHENSIVE QUOTE CONSIDERING AVAILABILITY OF ALL COMPONENTS, FOR AT CSIO WILL BE CONSIDERED.
2. THE REQUIRED QUANTITY IS MENTIONED AND COMPONENTS SHOULD BE SEALED/PACKED AS PER THE ORIGINAL FACTORY PACKING. IF FOUND DAMAGED, WILL BE RETURNED.
3. THE PRICE SHOULD BE INCLUDING EX-CSIO DELIVERY.
4. THE VALID COC SHOULD BE SHARED.
5. PAYMENT AND OTHER THINGS AS PER CSIO NORMS
6. PL MAIL AT head.pme@csio.res.in, harry.garg@csio.res.in,
7. QUOTE TIME 3 DAYS FROM DATE OF TENDER.
8. THE DETAILS OF USER WILL NOT BE SHARED.
9. SUPPLIER/OEM TO SHARE THE DELIVERY TIMELINES AFTER PO AND PAYMENT TERMS.. PURCHASE OF COMPONENTS/ PO IS PURELY THE PREROGATIVE OF CSIO.

NAME OF THE ITEM:

FABRICATION OF PCB, TESTING, OPTIMIZATION, CUSTOMIZATION, GERBER DATA GENERATION AS PER THE LAYOUT /SCHEMATICS ATTACHED .

Qty: 02 Nos

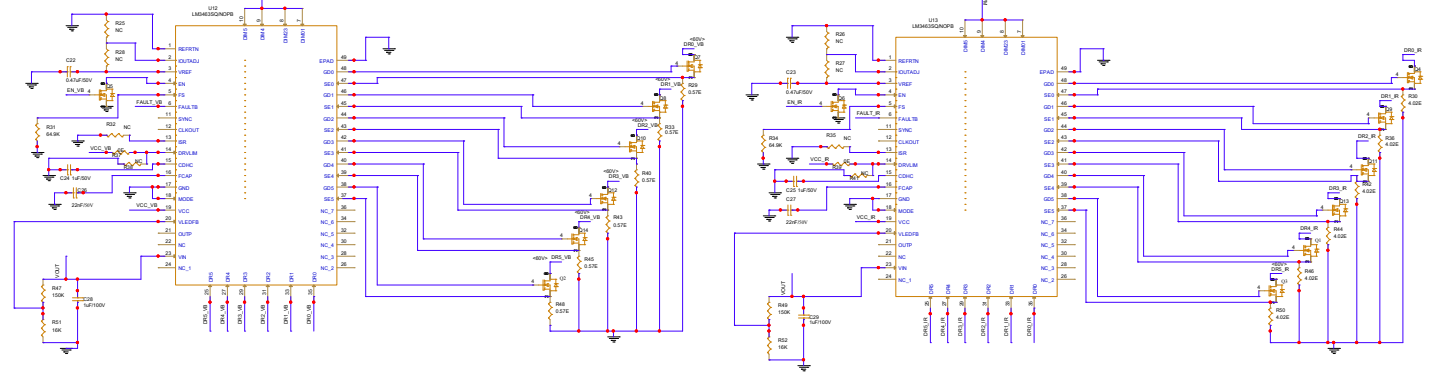
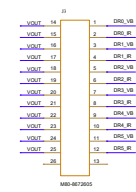
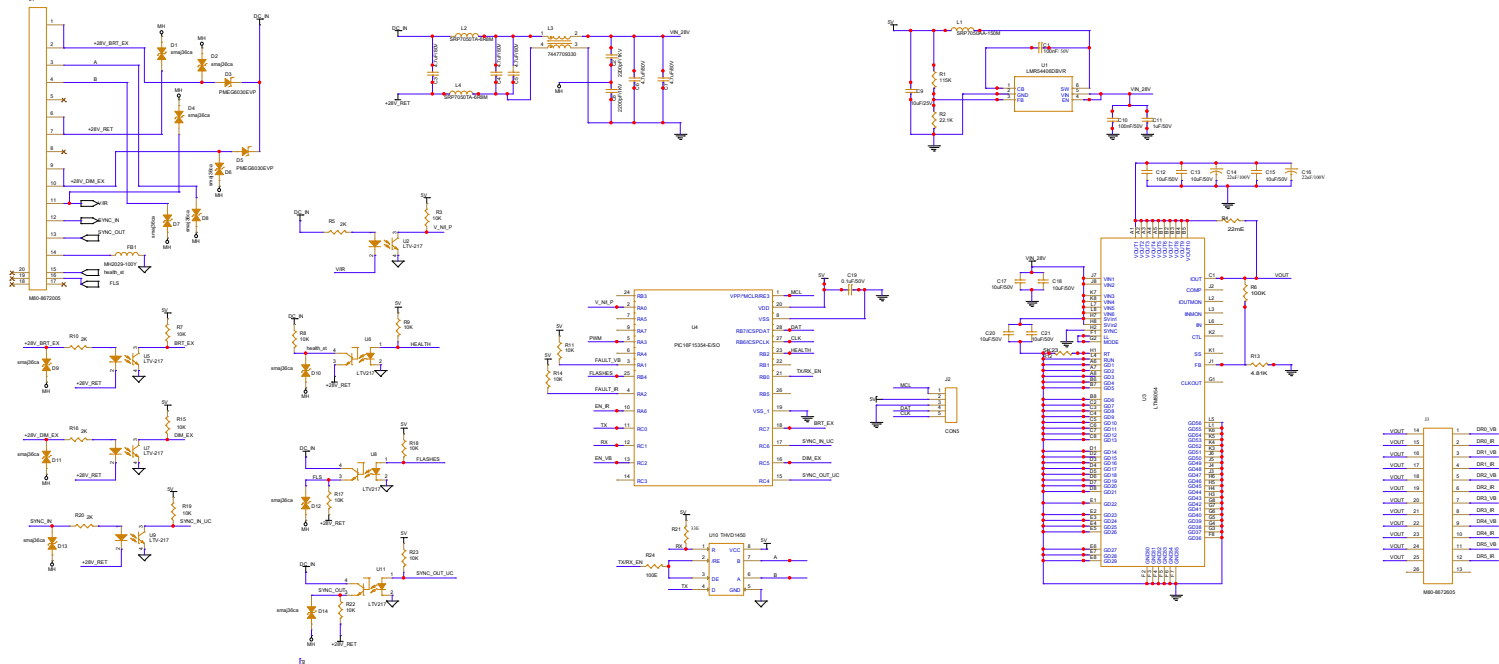

Rev	Changes
1	Initial Release
2	Design Changes
3	Final Release