



सीईएसआईआर - केन्द्रीय वैज्ञानिक उपकरण संगठन
CSIR-Central Scientific Instruments Organisation
सैक्टर 30 सी चंडीगढ़ Sector-30C, Chandigarh 160 030

Tender No.	CSIO/4(62)2018-Pur	Issue Date:	17 th December, 2018
Date & time of receipt of tender	2 nd January, 2019 upto 3.00 P.M	Date & time of opening of Tender	2 nd January, 2019 at 3.30 P.M.

We are interest to purchase the below given items/attached items. Kindly send your sealed Tender/Quotation/Proforma Invoice as per requirement. **Please refer all the terms & conditions overleaf before submission of tender.** The sealed envelope containing your quotation super scribed with our reference number and addressed to Director, CSIO should reach this office with the period as mentioned above. **Tenders/quotation received late will not be considered at all.** Tenders/quotation will be opened in the presence of supplier's representatives who wish to present themselves at that time.

Sr. No.	Description of Item	Quantity	Bid Type
	Fabrication of Gunsight components		Single Bid
1.	Lens Hosuing	11	
2.	Dazzle Cover	7	
3.	Dessicator	8	
4.	Dessicator pin	8	
5.	Filter Base	3	
6.	Intermediate Plate Adj	6	
7.	Graticule Cover	6	
8.	Graticule Hosuing	6	
9.	Base	6	
10.	Intermediate Plate	8	
11.	Front Lens	9	

Tender has been e-published on www.eprocure.gov.in. Prospective bidders are requested to get themselves registered on www.eprocure.gov.in for future also.

Yours faithfully,

(Mohinder Kumar)

(Controller of Stores and Purchase)

General Terms and Conditions

1. Please send your Proforma Invoice/Quotation with full specifications & literature showing FOB/FCA/CIP/CIF including inland Freight value. Cost of packing, forwarding, Air freight Transportation, if any, & Insurance charges may please be mentioned invariably, failing which the tender will be rejected. The gross weight of the consignment may be intimated in the Proforma Invoice to decide the mode of dispatch.
2. Offer/Bid for INR should be FOR, CSIO, Central Stores, Chandigarh. Taxes as are applicable should be indicated clearly failing which the offer shall not be considered. Bidder shall have to mention their GST No. Quotation shall be issued in the name of **DIRECTOR, CSIR-Central Scientific Instruments Organisation, Sector 30C, Chandigarh. GST No. is 04AAATC2716R1ZN.**
3. **Reasonability of Prices/Fall Clause**
 - i) Please quote best minimum prices applicable for a premiere Research Institution, leaving no scope for any further negotiations on prices.
 - ii) The quoting party should give a certificate to the effect that the quoted prices are the minimum and they have not quoted the same item on lesser rates than those being offered to CSIO to any other customer nor they will do so till the validity of offer or execution of the purchase order, whichever is later.
 - iii) Copies of atleast two recently supplied orders of the last two years received from other customers alongwith details of such supply orders preferably in India for the same item/model may be submitted with the offer giving reasons of price difference of their supply order & those quoted to us, if any. The party must give details of identical or similar equipment, if any, supplied to any CSIR lab during the last three years alongwith the final price paid and Performance certificate from them.
4. **Custom Duty & GST:** CSIR-CSIO is a R&D Govt. Organization & the requirement is for R&D purpose. CSIR-CSIO is exempted from IGST and Custom Duty under Govt. Notification No. 51/96-Custom dated 23.07.1996 and No. 24/2007 Dated 01.03.2007, no. 43/2017-Customs dated 30.06.2017 and government notifications no. 45/2017-Central Tax(Rate) & No. 45/2017-Intergrated Tax (rate) dated 14.11.2017. Only basic duty is applicable under this notification, hence bidders will have to submit their offer accordingly. We are exempted from payment of Custom Duty under notification No. 51/96 dated 23.07.1996. **Hence IGST and Custom Duty, if any, should be shown separately. No other charges than those mentioned clearly in the quotation will be paid.**
5. **Warranty:** Please mention the warranty period of equipment, which should be from the date of satisfactory installation.
6. Tenders/Quotations sent by FAX/E.mail are to be considered wherein EMD is not applicable at the risk of the bidders. Offers where EMD is required, the offers received through FAX/e.mail will not be considered at all.
7. **Validity:** The Proforma Invoice/Offer/Bid should not be less than 90 days from the date of opening of price bids otherwise your tender will be rejected.
8. **Liquidated Damages:** Being a Research and Development Organisation, time is essence of the order the date of delivery should be strictly adhered to. Otherwise the Competent Authority reserves the right not to accept the delivery in part of full and/or to claim the liquidated damages 0.5% per week subject to maximum 10% of ordered value.
9. **Agency commission:** Please mention the percentage of Indian Agency Commissioning which will be paid in Indian Currency. Also please intimate the complete details of Indian Agent
10. If the supplies has to be made through Indian Agent, please send us the copy of legal contract/agreement/latest specific authorization certificate indicating that the Indian Agent M/s _____ are authorized to quote on our behalf and the terms and conditions settled by the Indian Agents with the buyer will be binding on their Principals. Further an Indian Agent cannot quote on behalf of two different foreign suppliers. If they submit two offers on behalf of two different foreign suppliers, their offers may not be considered.
11. In case Indian Agent quotes in INR; they cannot ask for issue of CDEC & IGST levy both. However, we prefer to buy on High Sea Sales Agreement & payment shall be made on the basis of actual value indicated on Bill of Entry filed.
12. **Instructions for Indian Agents:** Agents in India of Foreign manufacturers shall submit alongwith the tender an income tax clearance certificate alongwith other relevant documents i.e. a copy of registration certificate from DGS&D in support of their being Agents of the foreign manufacturers
13. **Terms of Payment:** - Being a Govt. Organisation, no advance payment with the order or before dispatch of consignment of goods will be accepted. Terms of Payment are:-
 - (a) **Credit basis:** The payment will be made after receipt of the goods in good condition. The payment will be made through Electronic Clearance System (ECS). The complete bank details should be available on the offer as well on Invoice.
 - (b) **Sight Draft:** The payment will be released through our Banker only after receipt of material in good condition.
 - (c) **Letter of Credit:** The letter of credit for 100% of ordered value will be established against shipping documents subject to submission of Performance Bank Guarantee (PBG) for 10% of the ordered value for delivery + installation + warranty period + 60 days from the date of satisfactory installation.
 - (d) **Performance Bank Guarantee** for 10% of the ordered value is to be submitted by you/your Indian Agent for equipment costing Rs. 25.00 lakhs & above. .
14. If any amendment in L/C is required by the supplier, the amendment charges will be borne by them.
15. **Installation/Commissioning:** Equipment/Instruments are required to be commissioned/ installed/ demonstrated successfully immediately or within 30 days from the date of receipt of the system in CSIO by the the Principal or by their authorized Agent, failing which the Liquidated Damage Clause will be applicable
16. Certificate of undertaking that the equipment is of latest technology & will not be obsolete within 5 years after warranty will be attached with the offer. All essential spares parts of the offered equipment will available with the manufacturer or in India with your Indian Agents for a period of at least 5-7 years after warranty period which will be required at later stage.
17. All disputes, if any, subject to Chandigarh (India) jurisdiction. In case of dispute, the Arbitrator shall be appointed by the DG, CSIR, New Delhi (India).

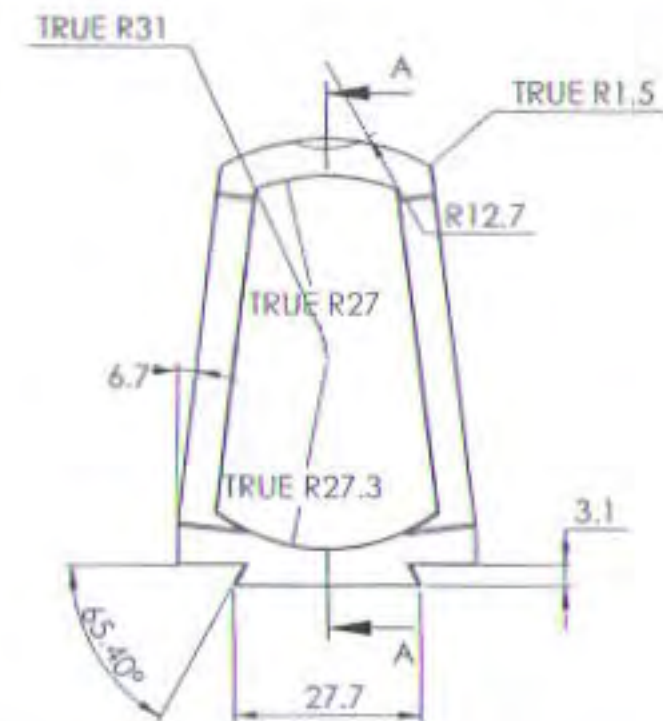
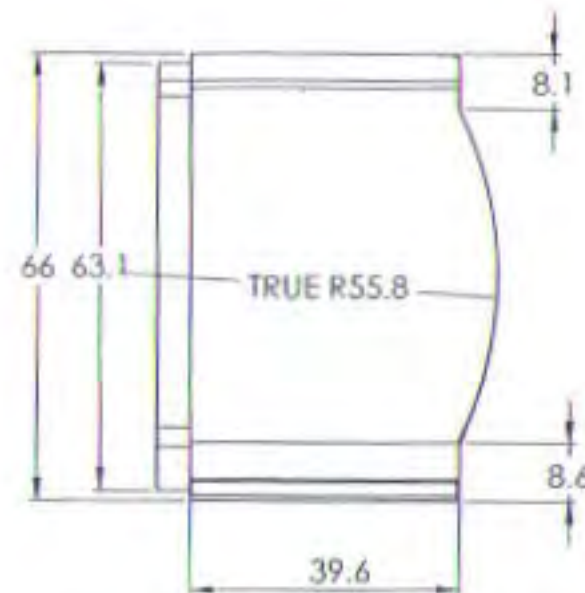
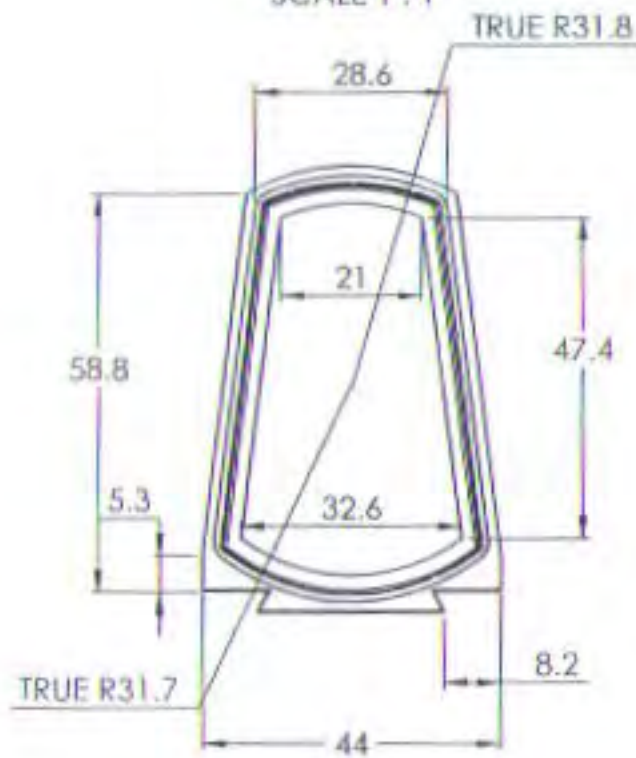
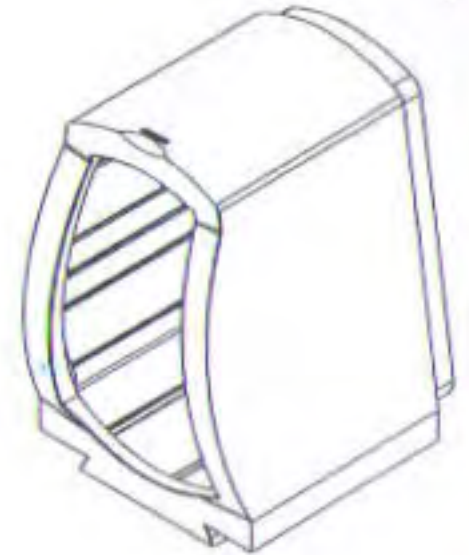
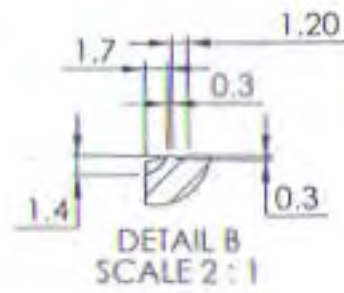
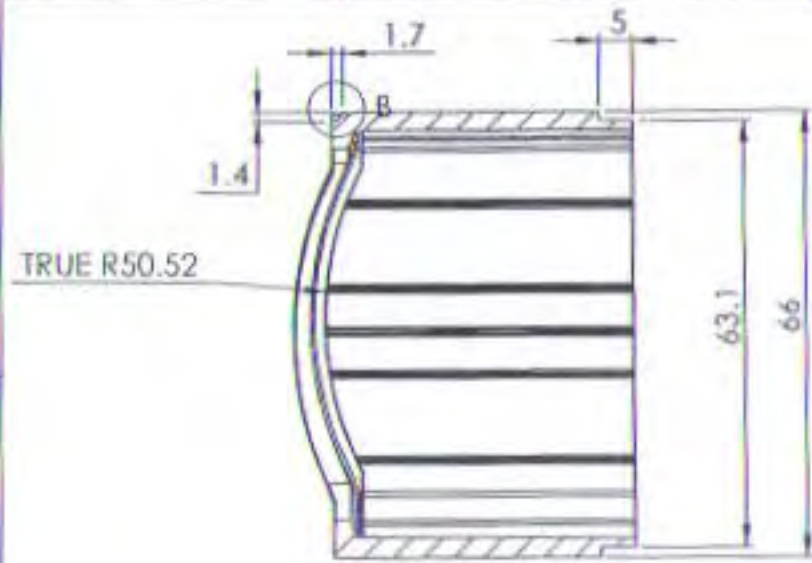

▽ (VV)

REMOVE SHARP EDGES & BURRS		TOL MET AFTER SURFACE TREATMENT	
PT NO. 43	NO. OFF: 1	A O P D CSIO CHANDIGARH	DRN 11-09-2018 HG
MATL: METALON			CHD 11-09-2018 SS
SIZE:		LENS HOUSING (GUN SIGHT)	PASD 11-09-2018 VK
SURFACE TREATMENT			APPD 11-09-2018 RCMA
REF: SR OP 0117		SCALE 1:1	
		SH 1 OF 1 SHS A3	

REV	CHANGE MADE	DATE	BY	APPD	GEN TOL IS: 2102(Part-1)-1980						
					ABOVE	0.5	3	6	30	120	315
					UP TO	3	6	30	120	315	1000
					TOL ±	0.05	0.05	0.1	0.15	0.2	0.3

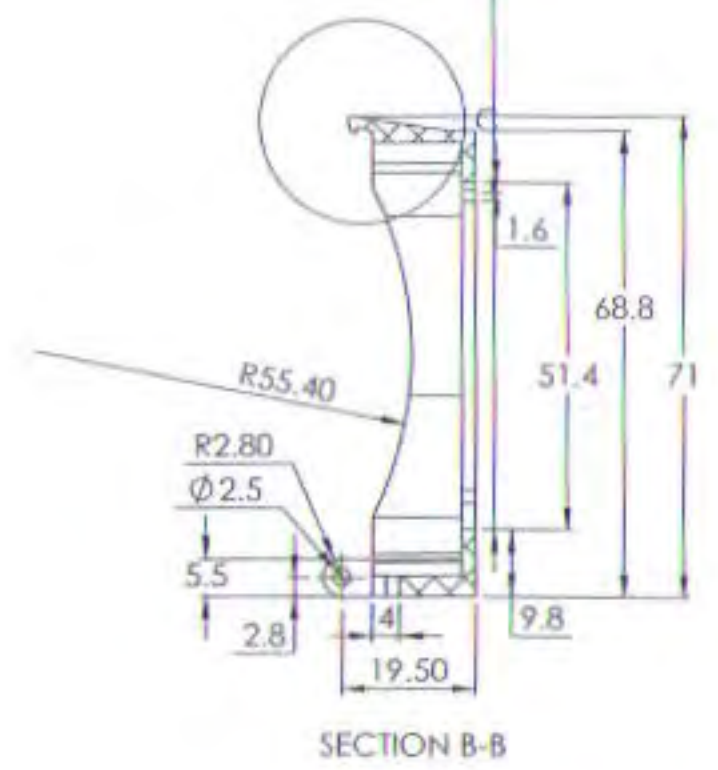
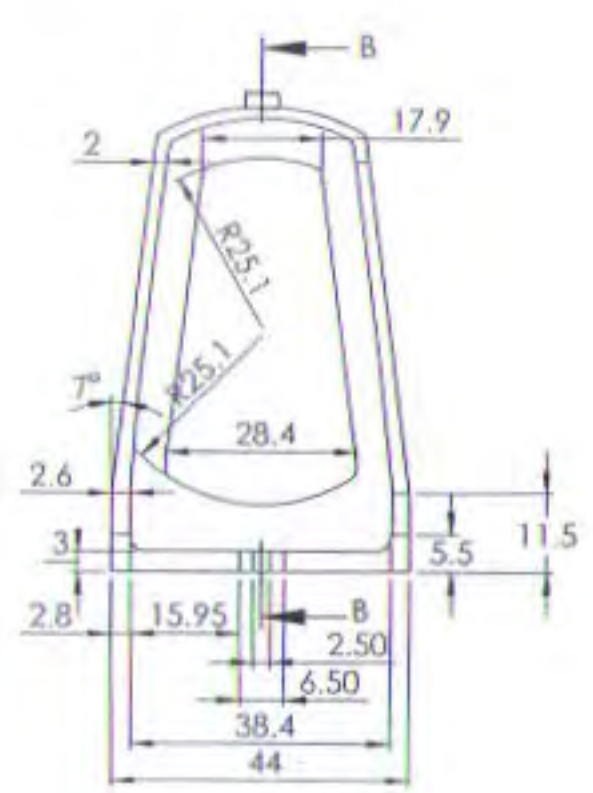
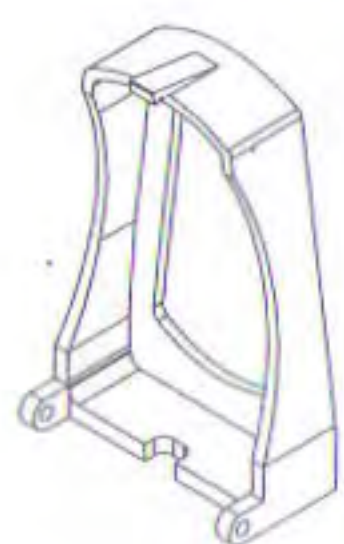
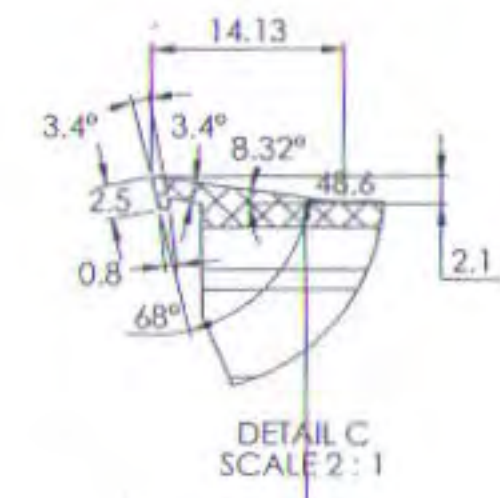
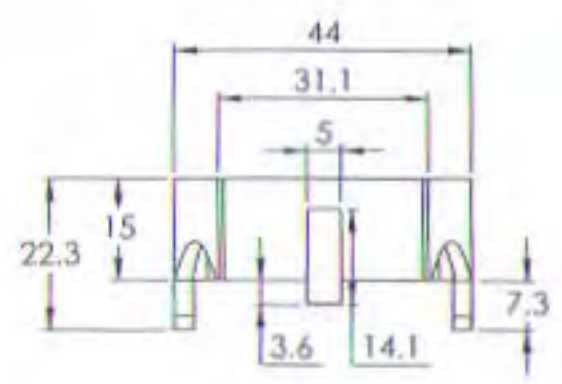

W(VVI)

REMOVE SHARP EDGES & BURRS		TOL MET AFTER SURFACE TREATMENT	
PT NO.: 14	NO. OFF: 1	A O P D CSIO CHANDIGARH	DRN 06-09-2018 HG
MATL: METALON			CHD 26-11-2018 SS
SIZE:		DAZZLE COVER (GUN SIGHT)	PASD 26-11-2018 VK
SURFACE TREATMENT			APPD 26-11-2018 RCMA
REF: SR OP 0117		SCALE 1:1	
		SH 1 OF 1 SHS A3	

REV	CHANGE MADE	DATE	BY	APPD	GEN TOL IS: 2102(Part-1)-1980
					ABOVE 0.5 3 6 30 120 315
					UP TO 1 6 30 120 315 1000
					TOL ± 0.05 0.05 0.1 0.15 0.2 0.3

REV	CHANGE MADE	DATE	BY	APPD	GEN TOL IS: 2102(Part-1)-1980						
					ABOVE	0.5	3	6	30	120	315
					UP TO	3	6	30	120	315	1000
					TOL +	0.05	0.05	0.1	0.15	0.2	0.3

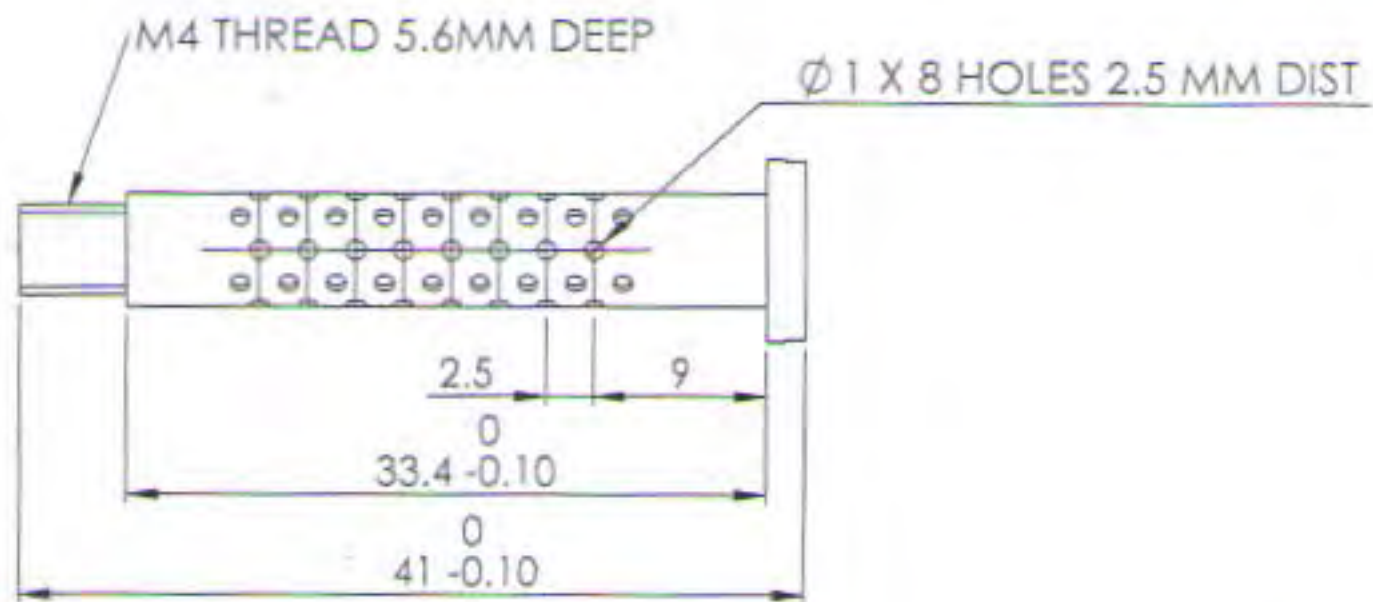
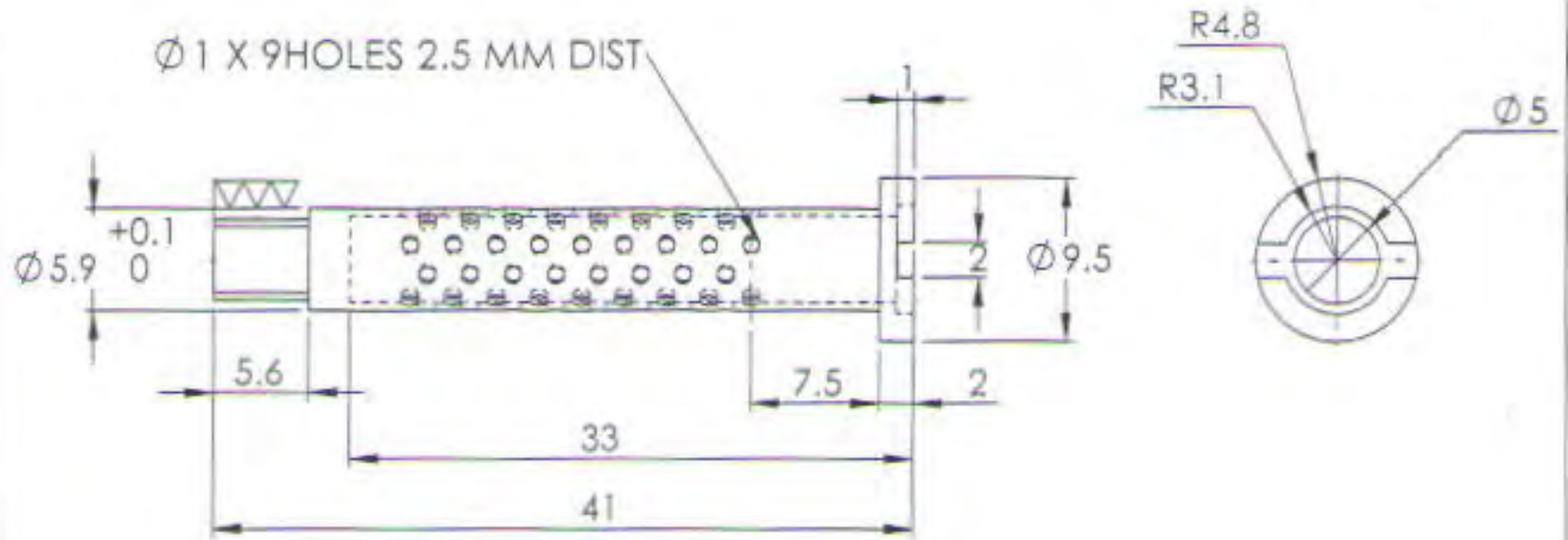
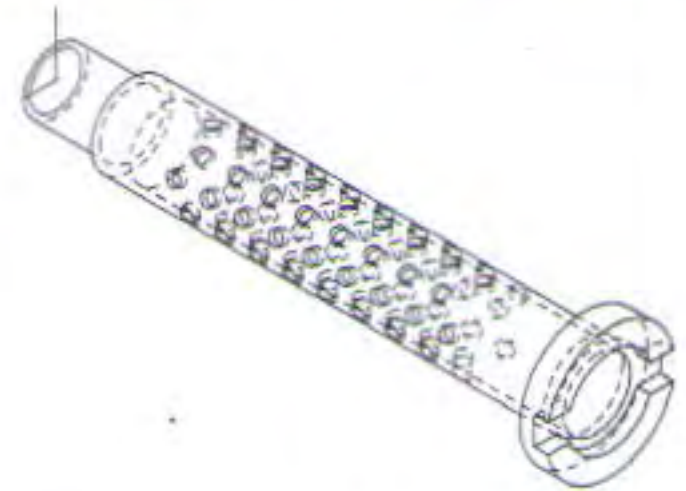

▽▽(▽▽)

REMOVE SHARP EDGES & BURRS		TOL MET AFTER SURFACE TREATMENT	
PART NO: 6	NO. OFF: 1	A O P D CSIO CHANDIGARH	DRN 8/14/2018 HG
MATL: AL. ALLOY 6063			CHD 8/29/2018 SS
			PASD 8/29/2018 VK
SURFACE TREATMENT			APPD 8/29/2018 RCMA
		REF: SR OP 0117	

REV	CHANGE MADE	DATE	BY	APPD	GEN TOL IS: 2102(Part-1)-1980						
					ABOVE	0.5	3	6	30	120	315
					UP TO	3	6	30	120	315	1000
					TOL +	0.05	0.05	0.1	0.15	0.2	0.3

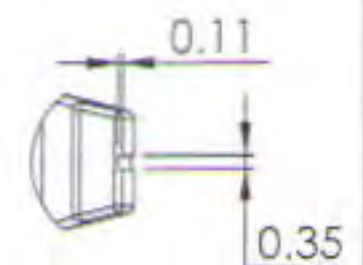
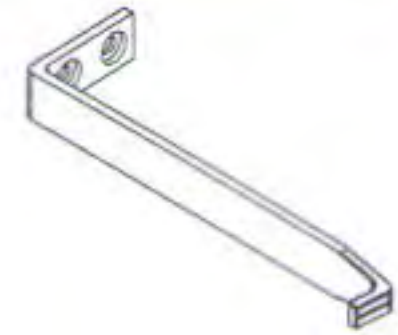

DETAIL B
SCALE 4 : 1

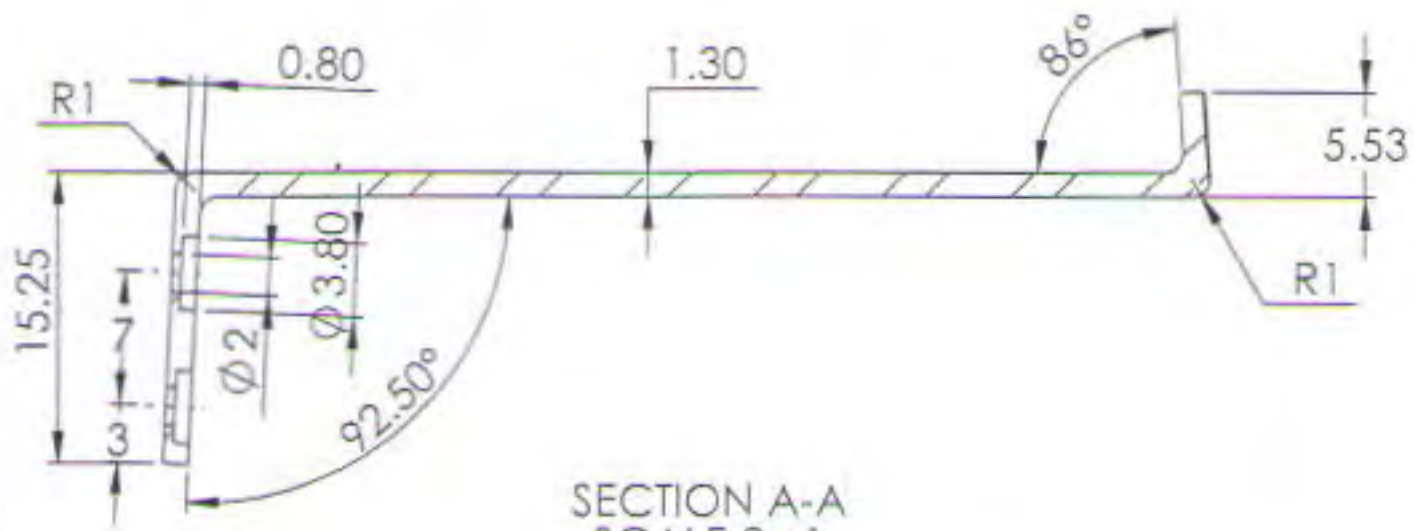

SECTION A-A
SCALE 2 : 1

REMOVE SHARP EDGES & BURRS		TOL MET AFTER SURFACE TREATMENT	
PART NO: 27	NO. OFF: 1	A O P D CSIO CHANDIGARH	DRN 11-09-2018 HG
MATL: MILD STEEL			CHD 08-10-2018 SS
SURFACE TREATMENT		DESSICATOR PIN (GUN SIGHT)	PASD 08-10-2018 VK
REF: SR OP 0117			APPD 08-10-2018 RCMA
			SCALE 2:1
			SH 1 OF 1 SHS A4

REV	CHANGE MADE	DATE	BY	APPD	GEN TOL IS: 2102(Part-1)-1980						
					ABOVE	0.5	3	6	30	120	315
					UP TO	3	6	30	120	315	1000
					TOL ±	0.05	0.05	0.1	0.15	0.2	0.3

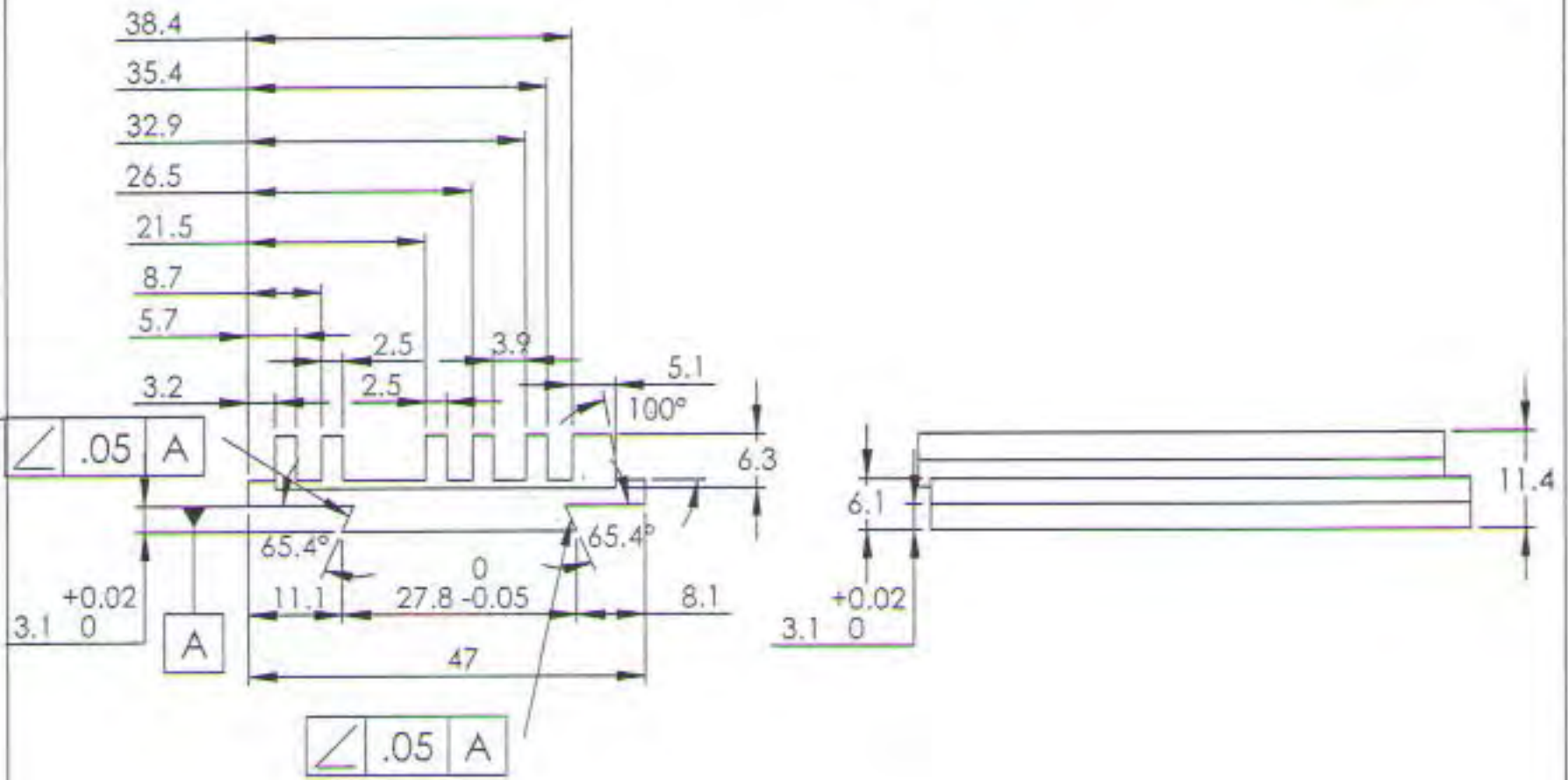
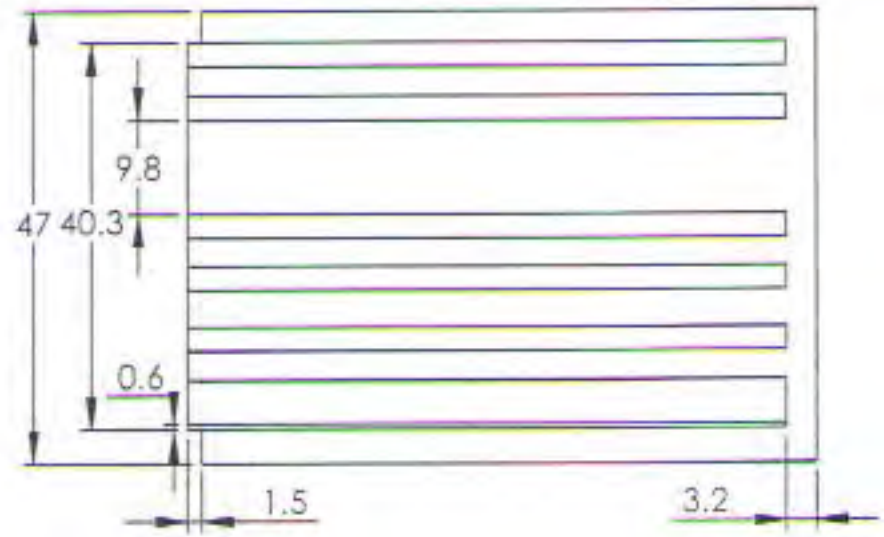

REMOVE SHARP EDGES & BURRS		TOL MET AFTER SURFACE TREATMENT			
PART NO: 28	NO. OFF: 1	A O P D	DRN	14-07-2018	HG
MATL: METALON			CHD	22-10-2018	SS
SURFACE TREATMENT		CSIO CHANDIGARH	PASD	22-10-2018	VK
			APPD	22-10-2018	RCMA
REF: SR OP 0117		FILTER BASE (GUN SIGHT)			SCALE 1:1
			SH 1 OF 1		SHS A4

REV	CHANGE MADE	DATE	BY	APPD	GEN TOL IS: 2102(Part-1)-1980						
					ABOVE	0.5	3	6	30	120	315
					UP TO	3	6	30	120	315	1000
					TOL +	0.05	0.05	0.1	0.15	0.2	0.3

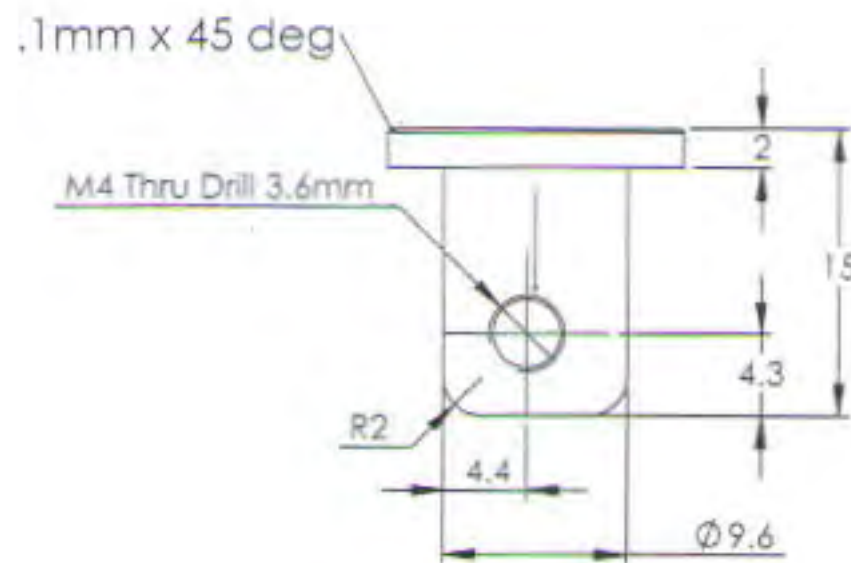
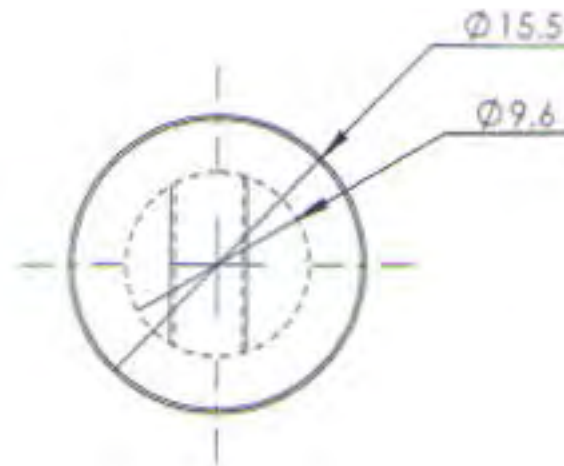

REMOVE SHARP EDGES & BURRS		TOL MET AFTER SURFACE TREATMENT			
PART NO: 20	NO. OFF:1	A O P D CSIO CHANDIGARH	DRN	26-07-2018	HG
MATL: NYLON			CHD	10-09-2018	SS
SURFACE TREATMENT		INTERMEDIATE PLATE ADJ. (GUN SIGHT)	PASD	10-09-2018	VK
REF: SR OP 0117			APPD	10-09-2018	RCMA
					SCALE 2:1
			SH 1 OF 1		SHS A4

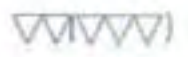
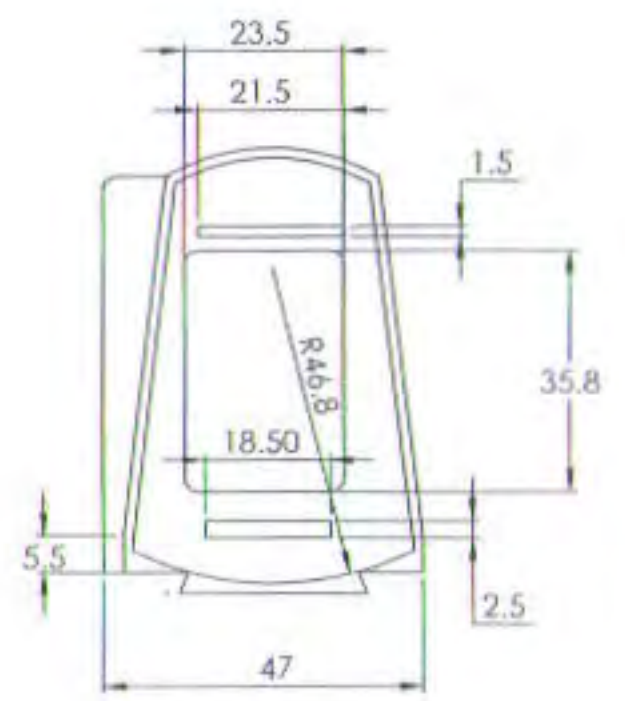
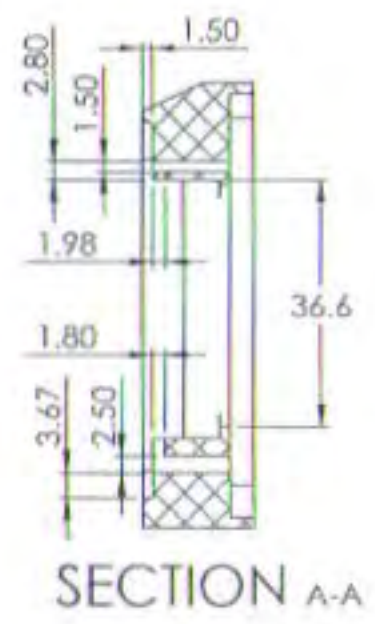
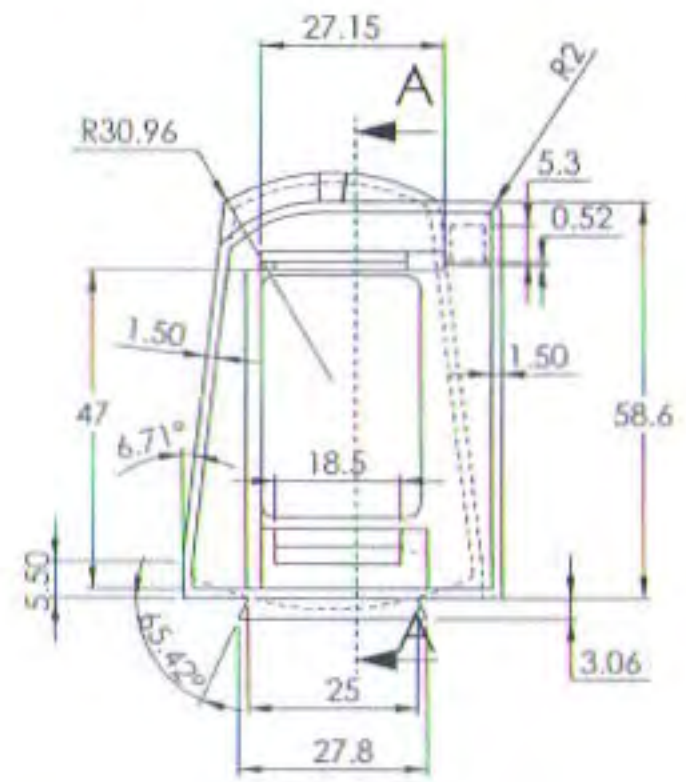
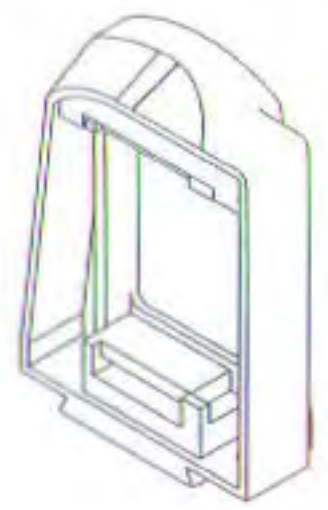
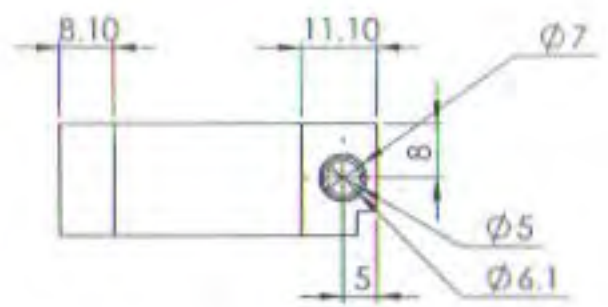
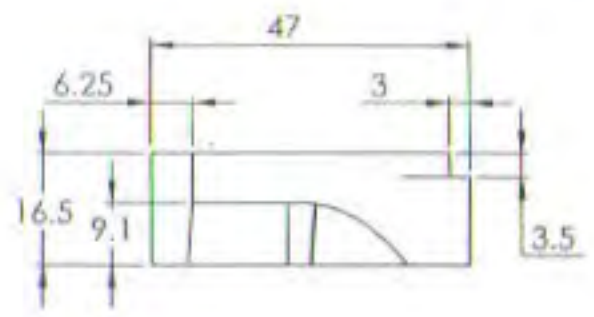

REV	CHANGE MADE	DATE	BY	APPD	GEN TOL IS: 2102(Part-1)-1980
					ABOVE 0.5 3 8 30 120 315
					UP TO 3 6 30 120 315 1000
					TOL ± 0.05 0.05 0.1 0.15 0.2 0.3

REMOVE SHARP EDGES & BURRS		TOL MET AFTER SURFACE TREATMENT	
PT NO.: 4	NO. OFF: 1	A O P D CSIO CHANDIGARH	DRN 26-07-2018 HG
MATL: METALON			CHD 11-09-2018 SS
SIZE:		GRATICULE COVER (GUN SIGHT)	PASD 11-09-2018 VK
SURFACE TREATMENT			APPD 11-09-2018 RCMA
REF:SR OP 0117		SCALE 1:1	
		SH 1 OF 1 SHS A3	

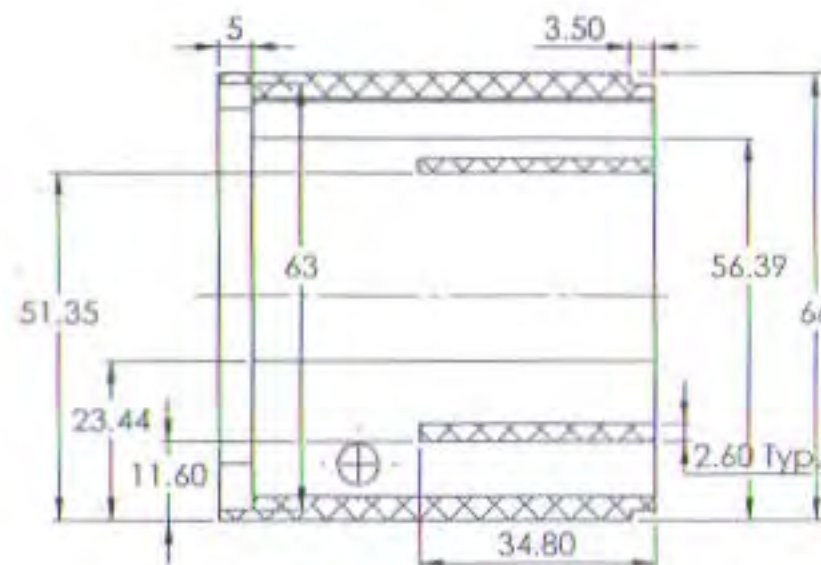
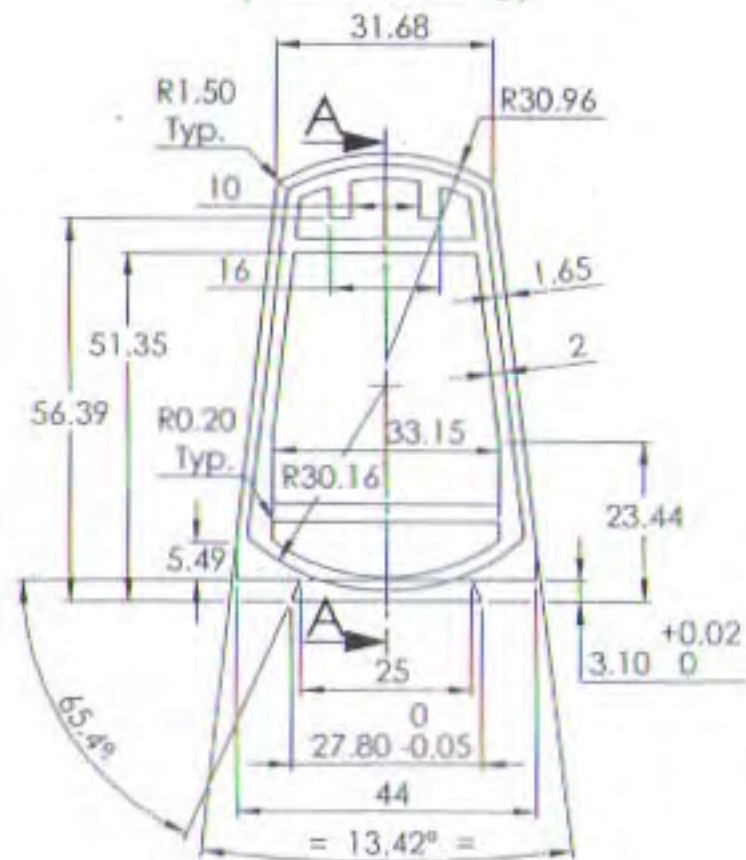
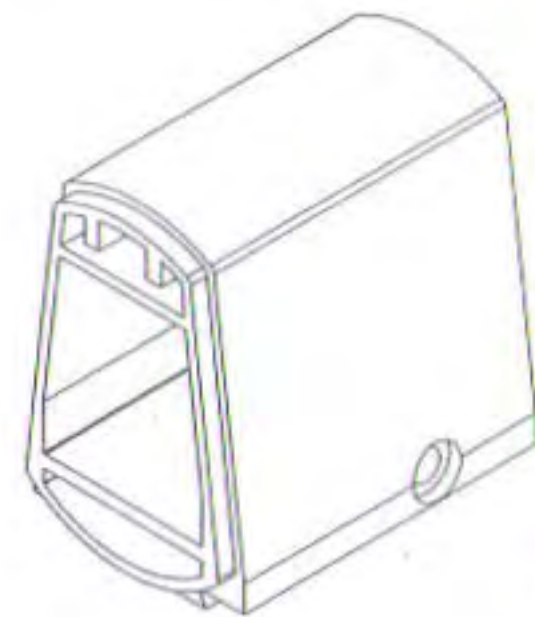
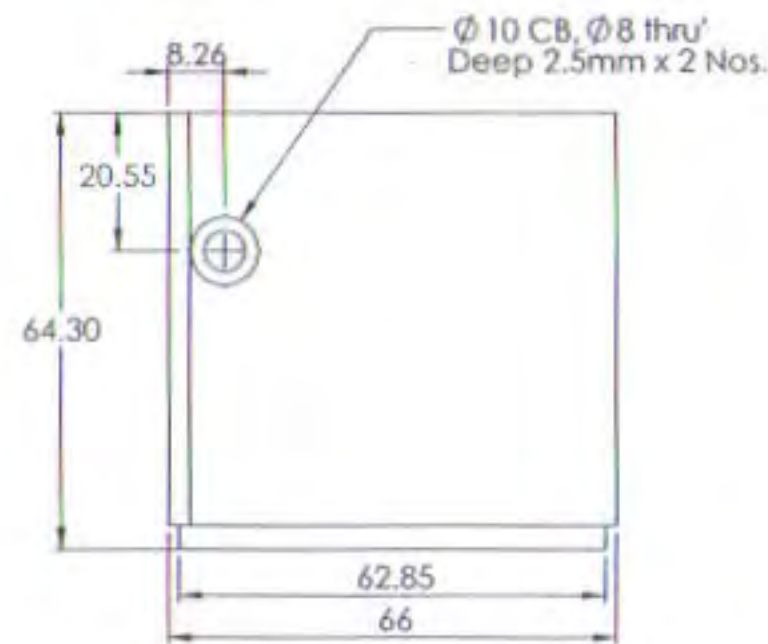
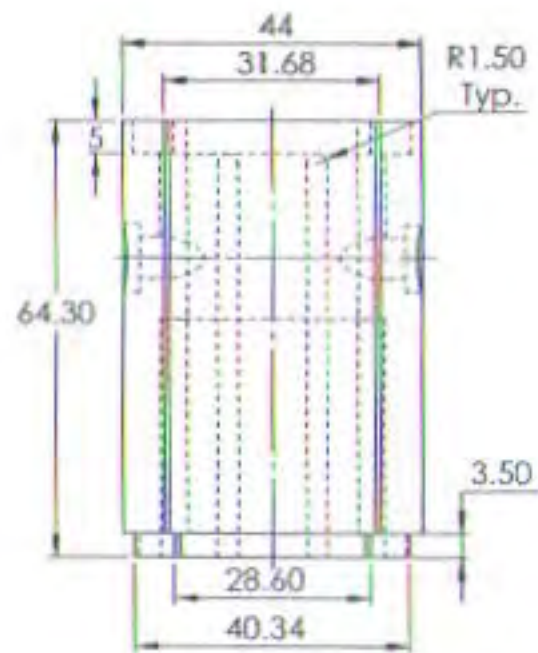

SECTION A-A

▽ (▽▽)

NOTE: ALL THE SHARP EDGE SHOULD BE CHAMFER WITH 0.5X45 Deg.

REMOVE SHARP EDGES & BURRS | TOL MET AFTER SURFACE TREATMENT

PT NO. 3	NO. OFF: 1	A O P D CSIO CHANDIGARH	DRN	02-08-2018	HG
MATL: METALON			CHD	10-09-2018	SS
SIZE:		GRATICULE HOUSING (GUN SIGHT)	PASD	10-09-2018	VK
SURFACE TREATMENT			APPD	10-09-2018	RCMA
SIZE:			SCALE 1:1		
REF:SR OP 0117		SH 1 OF 1		SHS A3	

REV	CHANGE MADE	DATE	BY	APPD	GEN TOL IS: 2102(Part-1)-1980						
					ABOVE	0.5	3	6	30	120	315
					UP TO	3	6	30	120	315	1000
					TOL +	0.05	0.05	0.1	0.15	0.2	0.3

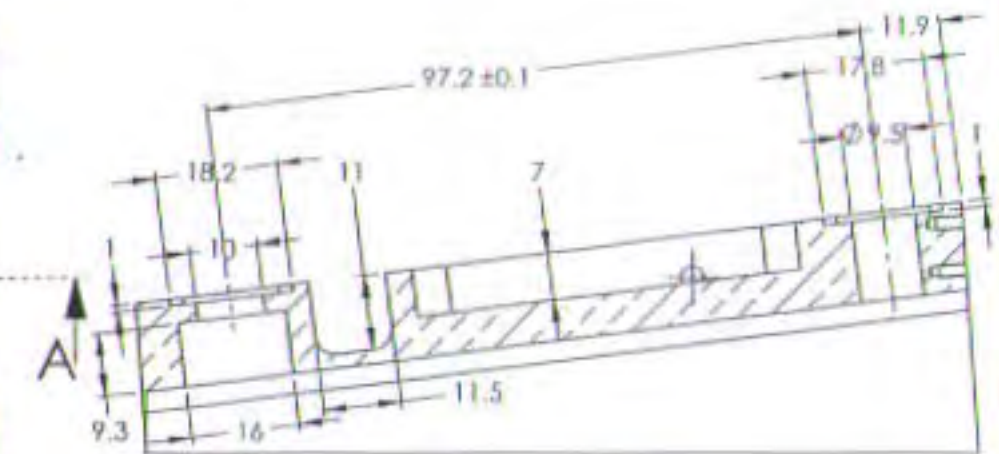
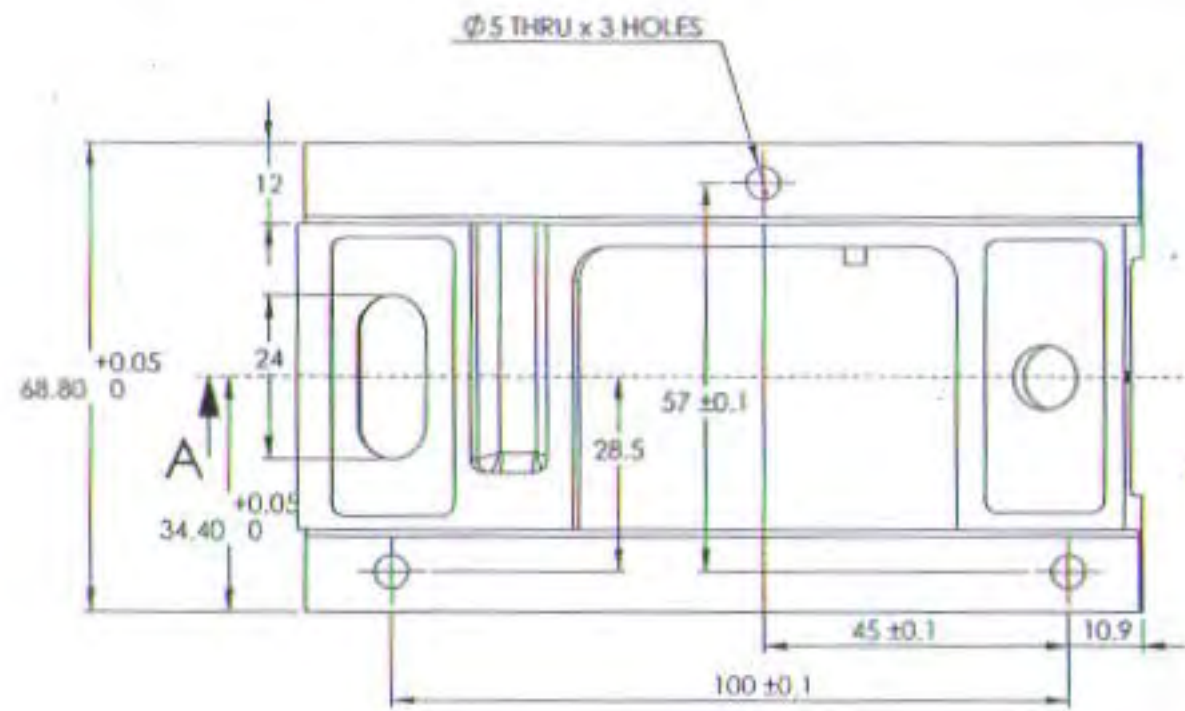

SECTION A-A
SCALE 1:1

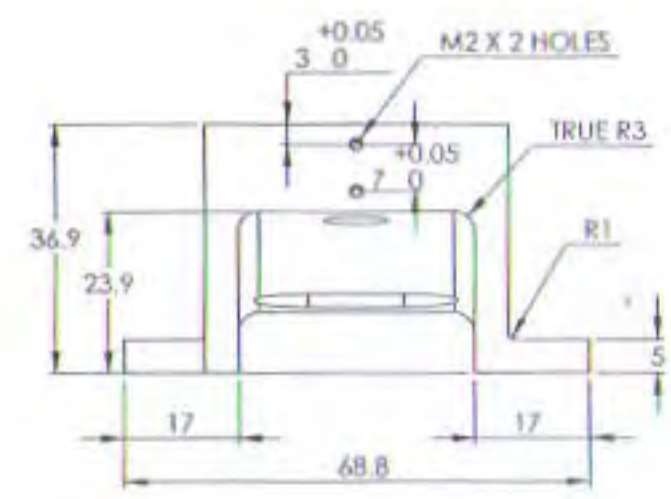
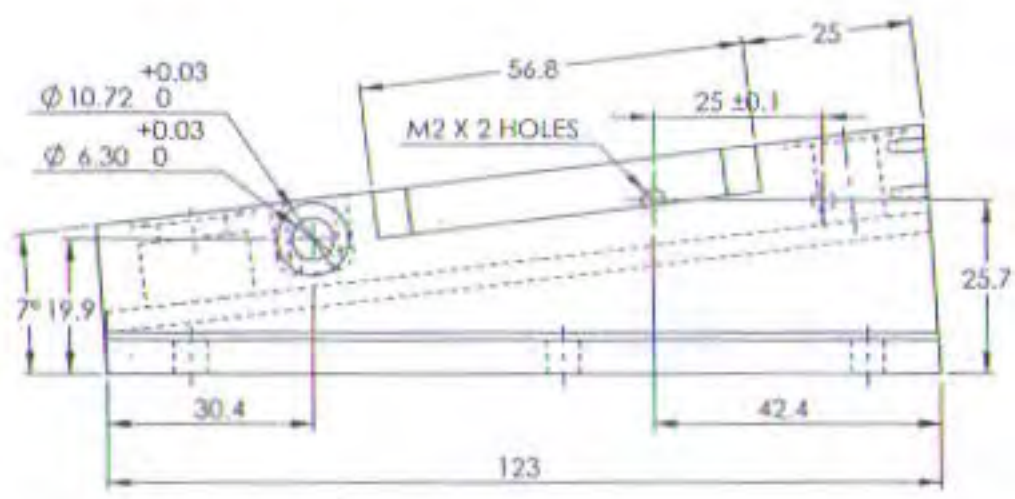
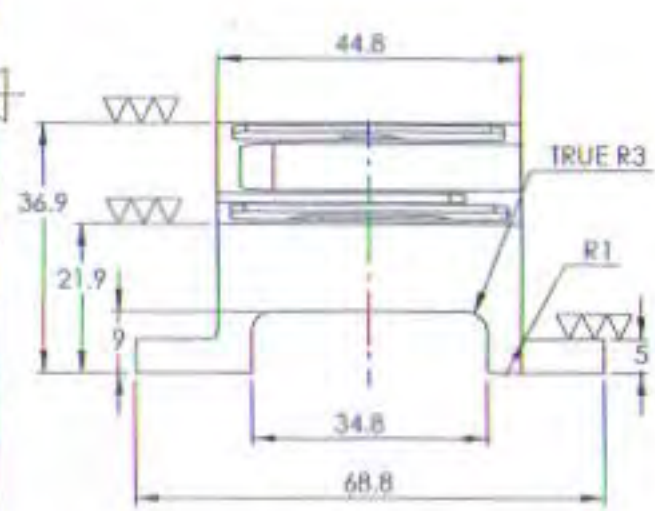

REV	CHANGE MADE	DATE	BY	APPD	GEN TOL IS: 2102(Part-1)-1980
					ABOVE 0.5 3 6 30 120 315
					UP TO 3 6 30 120 315 1000
					TOL + 0.05 0.05 0.1 0.15 0.2 0.3

REMOVE SHARP EDGES & BURRS		TOL MET AFTER SURFACE TREATMENT	
PT NO. 1	NO. OFF: 1	A O P D	DRN 7/4/2018 HG
MATL: AL ALLOY 6063			CHD 8/29/2018 SS
SIZE: SURFACE TREATMENT DULL BLACK ANODIZING		CSIO CHANDIGARH	PASD 8/29/2018 VK
			APPD 8/29/2018 RCMA
REF:SR OP 0117		BASE (GUN SIGHT)	SCALE 1:1
			SH 1 OF 1 SHS A3

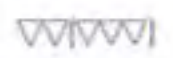
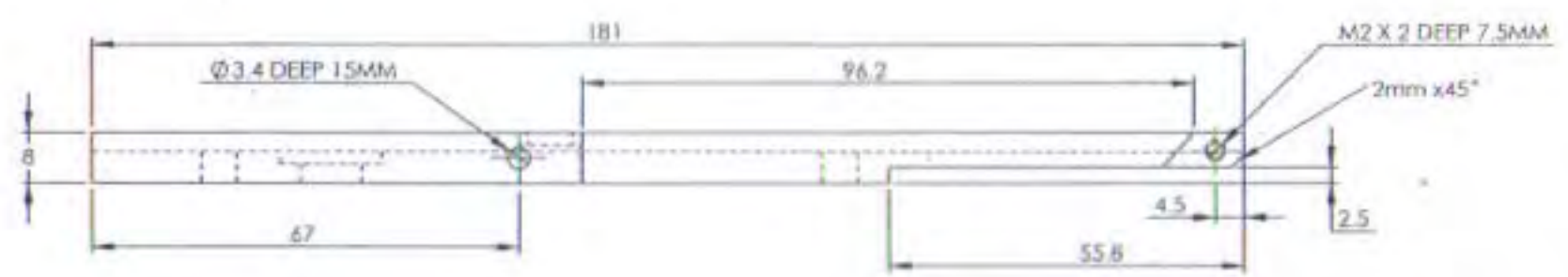
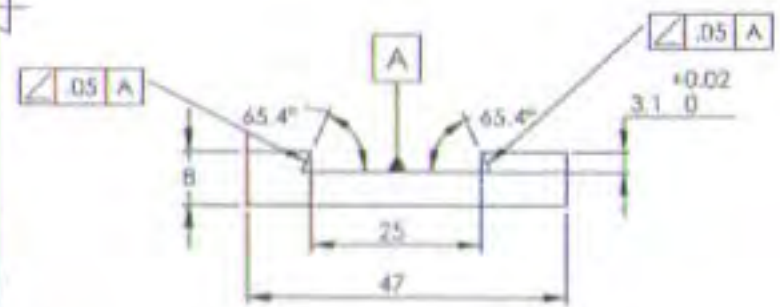
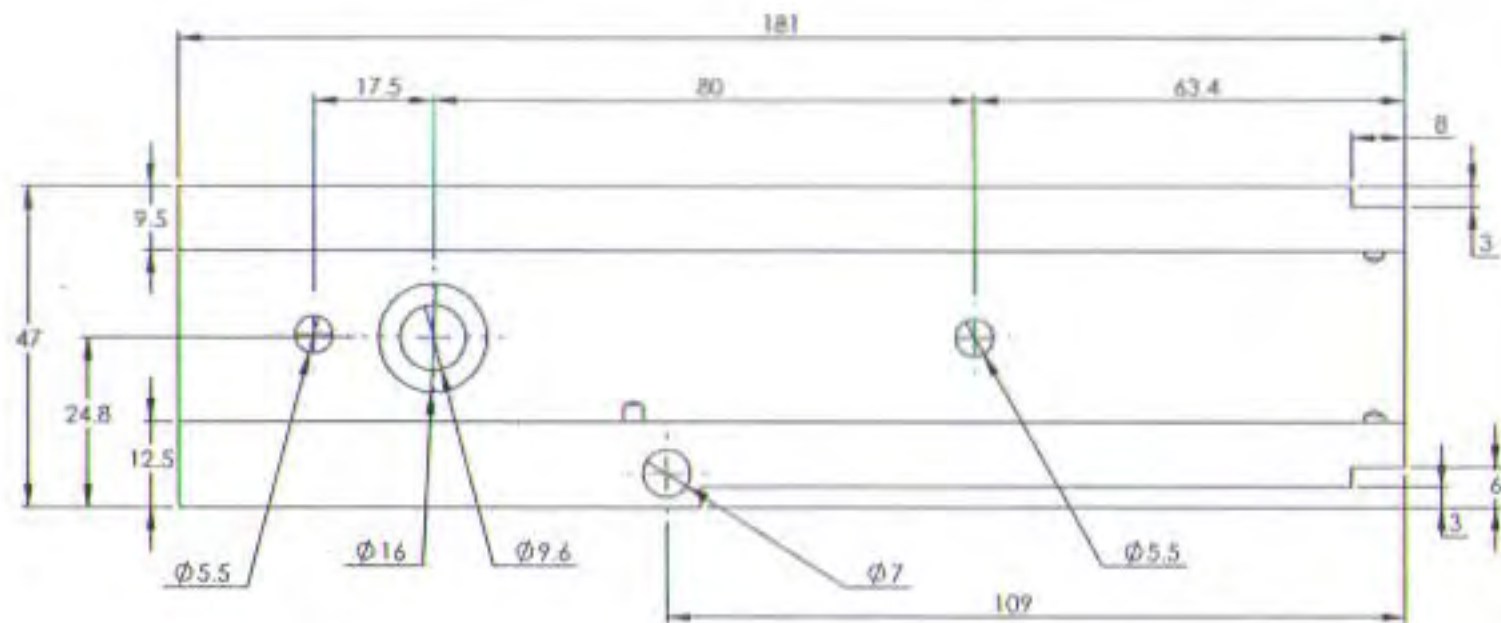

REMOVE SHARP EDGES & BURRS		TOL MET AFTER SURFACE TREATMENT	
PT NO. 2	NO. OFF: 1	A O P D CSIO CHANDIGARH	DRN 14-07-2018 HG
MATL: AL. ALLOY 6063			CHD 10-09-2018 SS
SIZE:		INTERMEDIATE PLATE (GUN SIGHT)	PASD 10-09-2018 VK
SURFACE TREATMENT			APPD 10-05-2018 RCMA
DULL BLACK ANODIZING			SCALE 1:2
REF: SR OP 0117		SH 1 OF 1 SHS A3	

REV	CHANGE MADE	DATE	BY	APPD	GEN TOL IS: 2102(Part-1)-1980
					ABOVE 0.5 3 6 30 120 315
					UP TO 3 6 30 120 315 1000
					TOL + 0.05 0.05 0.1 0.15 0.2 0.3

REV	CHANGE MADE	DATE	BY	APPD	GEN TOL IS: 2102(Part-1)-1980						
					ABOVE	0.5	3	6	30	120	315
					UP TO	3	6	30	120	315	1000
					TOL +	0.05	0.05	0.1	0.15	0.2	0.3

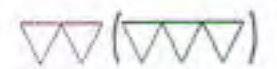
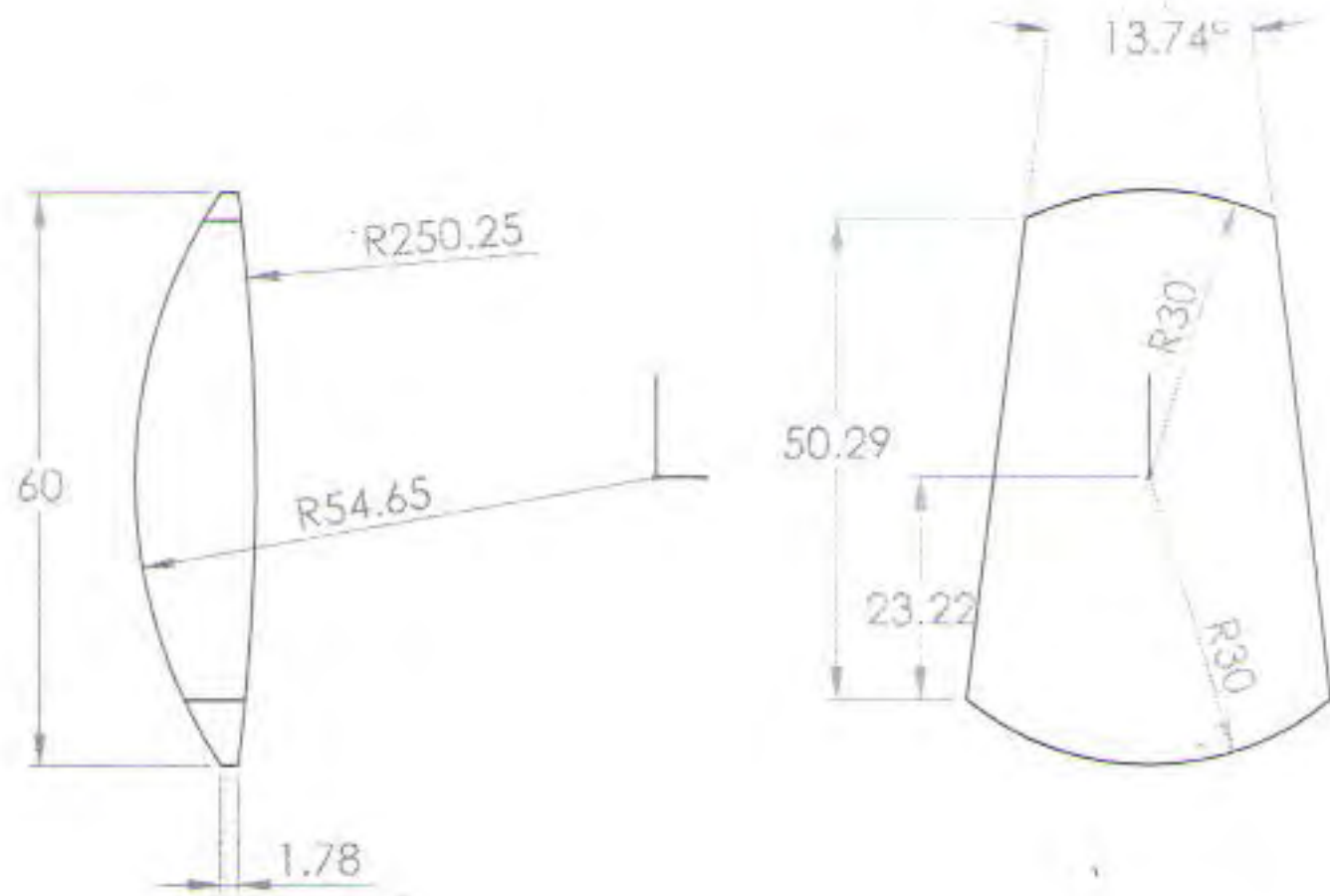

REMOVE SHARP EDGES & BURRS		TOL MET AFTER SURFACE TREATMENT	
PART NO: 10	NO. OFF:1	A O P D CSIO CHANDIGARH	DRN 06-08-2018 HG
MATL: GLASS			CHD 01-09-2018 SS
SURFACE TREATMENT		FRONT LENS (GUN SIGHT)	PASD 01-09-2018 VK
REF: SR OP 0117			APPD 01-09-2018 RCMA
			SCALE 1:1
			SH 1 OF 1 SHS A4