

IN-SITU NITRATE DETECTION IN GROUNDWATER WITH EARLY WARNING SYSTEM

Navneet Singh Aulakh*, R. S. Kler
Central Scientific Instruments Organisation (CSIR), Chandigarh
*scientistq@yahoo.com

Abstract: This paper presents an edge filtering technique based interrogator for fiber Bragg grating sensors with microbend attenuation compensation system for in-situ nitrate detection in groundwater. The interrogator uses reference fiber along with the fiber in which the grating is inscribed to mitigate the effect of microbend attenuation in determining the Bragg wavelength of the sensor.

1. INTRODUCTION

Since the output of a Bragg grating sensor is present in the wavelength domain it requires sophisticated circuits to measure wavelength shift. A few approaches were developed to solve this problem [1]. One way of interrogating a Bragg grating sensor is to use a tunable filter. One example is the Fabry-Perot interferometer with a cavity length controlled by a piezoelectric actuator. Although this approach has a good resolution and is independent of light intensity variations, it is relatively slow and expensive. Chirped fiber Bragg grating (CFBG) can also be used as the wavelength-sensitive component [2]. A chirped Bragg grating can be used as a device that converts wavelength into delay. For example, a typical grating of 10 cm in length corresponds to a maximum delay of 1 ns. By measuring this delay, we can find the wavelength of light corresponding to the delay. Very fast electronic circuitry is required for resolving this delay and it proves to be very expensive. The use of an edge filter is an inexpensive way of measuring Bragg wavelength shift but the accuracy is impaired by microbend losses that occur in the fiber connecting the Fiber Bragg Grating Interrogator to the Fiber Bragg Grating. This paper presents the technique to circumvent this problem.

2. EXPERIMENT & RESULTS

The errors induced due to intensity fluctuations because of microbending are reduced by employing corrections based on the intensity modulation in the

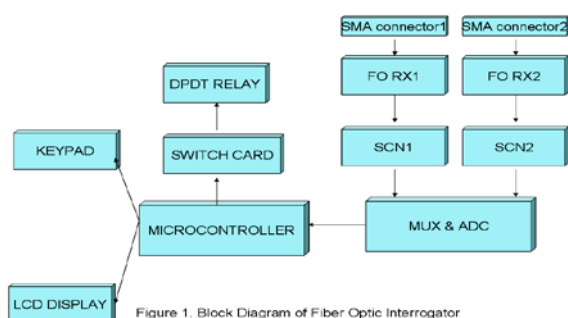
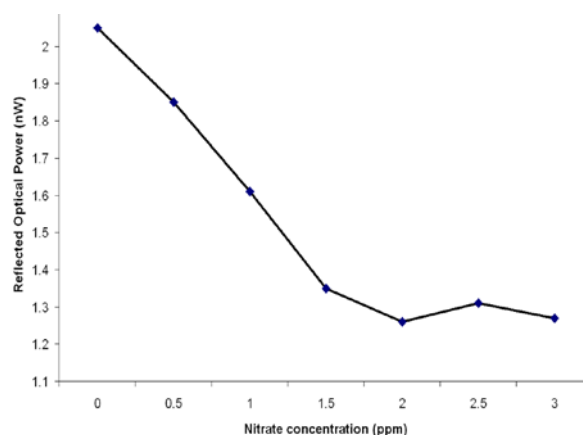

Figure 1. Block Diagram of Fiber Optic Interrogator

reference fiber. The block diagram of the experimental arrangement is shown below

As shown in the Figure the Fiber Optic Receiver converts the light intensity from the optical fiber fixed at the SMA connector into an electrical signal. This signal is then amplified and given to filter circuit which conditions the signal to be input to the ADC. The Analog to digital converter converts the analog signal into digital which is given to the microcontroller to be analyzed. The experimental results demonstrate increased precision in the nitrate detection using this technique.



Compact, rugged and low cost Fiber Bragg Grating Interrogators can be designed using this technique.

3. ACKNOWLEDGEMENT

The authors wish to acknowledge gratefully the support from CSIR

4. REFERENCES

- [1] Gaozhi Xiao; Mrad, N.; Fang Wu; Zhiyi Zhang; Fengguo Sun, "Miniaturized Optical Fiber Sensor Interrogation System Employing Echelle Diffractive Gratings Demultiplexer for Potential Aerospace Applications," Sensors Journal, IEEE , vol.8, no.7, pp.1202-1207, July 2008

- [2] Sheng Liang; Swee Chuan Tjin; Nam Quoc Ngo; Zhengqian Luo; Yingsong Wang; Changyong Tian, "Novel Tunable Fiber Optic Edge Filter Based on Modulating Chirp Rate of π -Phase-Shifted Fiber Bragg Grating," PhotonicsGlobal @Singapore, 2008. IPGC 2008. IEEE , vol., no., pp.1-4, 8-11 Dec. 2008